

COLOR CRT MONITOR

DOC. NO	KT-XX14X-SM
DATE	2004 .02. 02
REV. NO	0
REV. DATE	-

SERVICE *MANUAL*

KT-2914F / KT-2914DF

KT-2114F / KT-2114DF



KORTEK CORPORATION

CONTENTS

1. PRECAUTIONS	3
2. PRODUCT SPECIFICATION	6
3. OPERATING INSTRUCTION	9
4. ADJUSTMENTS	11
5. TROUBLE SHOOTING GUIDE	19
6. PART LIST	29
7. BLOCK DIAGRAM	34
8. CONNECTING DIAGRAM	35
9. SCHEMATIC	36
10. PRINT CIRCUIT BOARD	37

1. Precautions

1-1. Safety precautions

Warnings : Service should not be attempted by anyone unfamiliar with the necessary on this Monitor.

The followings are the necessary precautions to be observed before servicing.

- 1) For continued safety, do not attempt to modify the circuit board.
- 2) Disconnect the AC power before servicing.
- 3) When the chassis is operating, semiconductor heat sinks are potential shock hazards.

1-1-1 Servicing the high voltage volume are CRT Warnings

A High Voltage volume replaced in the wrong direction may cause excessive X-Ray emissions.

- 1) Adjust in order to 26KV with signal at Anode.
- 2) When the troubleshooting a monitor with excessively High Voltage, avoid being unnecessarily close to the monitor. Do not operate the monitor for longer than is necessary to locate the cause of excessive voltage.
- 3) Excessive High Voltage can produce potentially hazardous X-Ray RADIATION. To avoid such hazards, the high voltage must be above the specified limit. The nominal value of the High voltage of this Monitor is 26KV \pm 0.3KV at zero beam current(minimum brightness) under a 120V AC power source. The High Voltage must not (under any circumstances) exceed 29KV. Each time a monitor requires servicing, the High Voltage should be checked following the High Voltage check procedure on this manual. It is recommended the reading of the voltage be recorded as a part of the service record. It is important to use an accurate and reliable High Voltage meter.
- 4) When the High Voltage regulator is operating properly, there is no possibility of an X-Ray problem.
- 5) The CRT is especially designed to prohibit X-ray emission. To ensure continued X-ray protection, replace the CRT only with one that is the same or equivalent type as the original.
- 6) Handle the CRT only when wearing shatterproof goggles and after completely.
- 7) Do not lift the CRT by the neck.

1-1-2. Fire and Shock Hazard

Before returning the monitor to the user, perform the following safety checks:

- 1) Inspect each lead dress to make certain that the leads are not pinched or that hardware is not lodged between the chassis and other metal parts in the monitor.
- 2) Inspect all protective devices such as nonmetallic control knobs, insulating materials, cabinet backs, adjustment and compartment cover or shields isolation resistor-capacitor networks, mechanical insulations, etc.
- 3) To be sure that no shock hazard exists, check for leakage current in the following manner.
 - a. Plug the AC line cord directly into a 120 or 230 Volt AC outlet.
(Do not use an isolation transformer for this test)
 - b. Using two clip leads, connect a 1.5K , 10Watt resistor paralleled by a 0.15Uf capacitor in serial with an exposed metal chassis part and a known earth ground, such as an electrical conductor and electrical ground connected to a earth ground.
 - c. Use a SSVM or VOM with 1000 ohms per-volt or sensitivity to measure the AC voltage drop across the resistor.
 - d. Connect the resistor to an exposed metal part having a return path to the chassis(metal cabinet, screw heads, knobs, shafts, escutcheon,etc) and measure the AC voltage drop across the resistor.
 - e. Any reading of 5.25 volt RMS(this corresponds to 3.5 milliampere AC) or more is excessive and indicates a potential shock hazard. Correct the shock hazard before returning the monitor to the user.

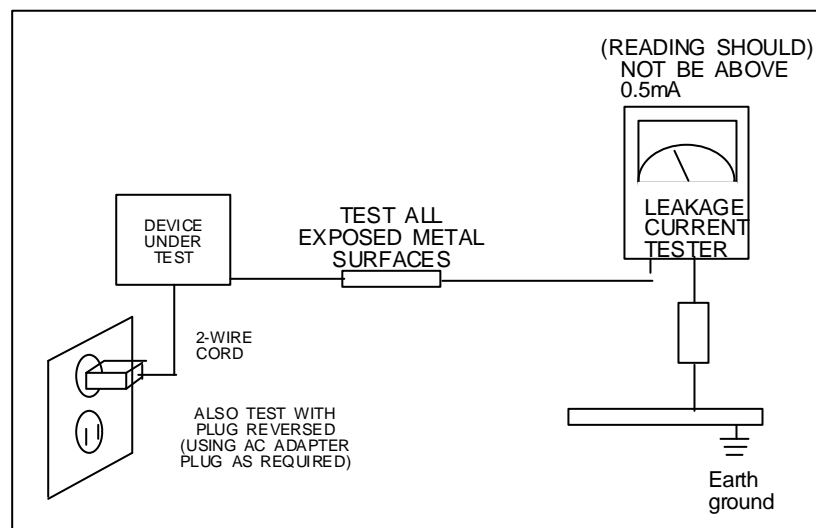

Figure 1-1. Leakage Current Test Circuit

1-1-3. Product safety notices:

Some electrical and mechanical parts have special safety related characteristics which are often not evident from visual inspection. The protection they give may not be obtained by replacing them with components rated for higher voltage, wattage, etc. Parts that have special safety characteristics are identified by on schematics and parts lists.

A substitute replacement that does not have the same safety characteristics as the recommended replacement part might create shock, fire and or other hazards. Product safety is under review continuously and new instructions whenever appropriate.

1-2. Servicing Precautions

WARNING 1 : First read the "Safety Precaution" section of this manual. if unforeseen circumstances create conflict between the servicing precautions and safety precautions, always follow the safety precautions.

WARNING 2 : A High Voltage volume replaced in the wrong direction may cause excessive X-ray emissions.

WARNING 3 : An electrolytic capacitor installed with the wrong polarity might explode.

- 1) Servicing precautions are printed on the chassis, and should be followed closely
- 2) Always unplug the units AC power cord from the AC power source before attempting to : (a) remove or reinstall any component or assembly, (b) disconnect PCB plugs or connectors, (c) connect all test components in parallel with an electrolytic capacitor.
- 3) after servicing, always check that the screws, components and wiring have been correctly reinstalled. Make sure that the area around the serviced part has not been damaged.
- 4) Check the insulation between the blades of the AC plug and accessible conductive parts (examples: metal panels, input terminals and earphone jacks).
- 5) Never defeat any of the +B voltage interlocks. Do not apply AC power to the unit (or any of its assemblies) unless all solid-state heat sinks are correctly installed.
- 6) Always connect a test instruments ground lead to the instrument chassis ground before connecting the lead; always remove the instruments lead last.

2. Product Specifications

2-1 SPECIFICATION

CDT		KT-2914F	KT-2914DF	KT-2114DF	KT-2114F	
	Tube		29"Normal flat	29"Dyna flat	21"Dyna flat	21"Normal flat
Tube Size(Diagonal)		730mm(29")	730mm(29")	550mm(21")	550mm(21")	
Viewable Size(Diagonal)		605mm(27")	605mm(27")	508mm(20")	508mm(20")	
Dot Pitch		0.79mm(H)	0.79mm(H)	0.74mm(H)	0.74mm(H)	
Deflection Angle		90 °	90 °	90 °	90 °	
Focusing Method		Single	Double	Single	Single	
Display Area (mm)	Normal (H*V)	550*400	550*400	400*300	400*300	
	Maximum (H*V)	580*410	580*410	415*310	415*310	
Bandwidth	Maximum	50MHz				
Scanning Frequency (Auto Scanning)	Horizontal	15-40KHz				
	Vertical	50-120Hz				
Microprocessor	User Saving Mode	6 Modes				
User Control Display	Digital	Position,Size,Pincushion,Trapezoid,H/Vcorner, Pin-B,Trapezoid,Parallel,Tilt,Moire,Zoom Color Temperature,Recall,Manual Degauss				
	Language	Eng/Ger/Fra/Esp/Port				
Display color	Color Temperature	9300 K, 6500 K, User Color				
Resolution	Maximum Mode	800 X 600 @ 60Hz				
Signal Input	Connect	15 pin D-sub(Female) or Option(6Pin, 5Pin)				
Safety & EMC	Safety	cUL,CE,DHHS				
	EMC	FCC,CE				
Power	Voltage	AC 90-264V, 60 / 50 ±3Hz				
Power Consumption	Nomal Operation	120 Watts				
	Input Current at 120V	Operating : 1.5Amps rms. Turn on : 30Amps Peak.				
	Input Current at 240V	Operating : 0.8Amps rms. Turn on : 60Amps Peak.				
Linearity	Cross Pattern	Horizontal : 5% Vertical : 5%				
Environment	Temperature	Operating : 0 to +40 Storage : -40 to +60				
	Humidity	Operating : 10 to 85% Storage : 5 to 95%				

2-2 D-SUB SIGNAL CABLE SPECIFICATION

* VGA/SVGA SIGNAL CABLE PIN CONNECTION (15 PIN D-SUB MINIATURE SIGNAL CONNECTOR WITH CABLE ; PCB CKT NO.: CN404)

CONNECTION				REMARK
D-SUB 15PIN	IBM PC	WIRE COLOR	6P CONN 6P CONN	
1	RED	RED COAX-IN	6P CONN-6	
2	GREEN	GREEN COAX-IN	6P CONN-5	
3	BLUE	BLUE COAX-IN	6P CONN-4	
4	N.C	-	-	
5	GND	BLACK	6P CONN-3	
6	RED-GND	-	RING WIRE	
7	GREEN-GND	-		
8	BLUE-GND	-		
9	N.C	-	-	
10	ID	-	-	
11	N.C	-	-	
12	SDA	-	-	
13	H-SYNC (C/S)	ORANGE	6P CONN-1	
14	V-SYNC	WHITE	6P CONN-2	
15	SCL	-	-	
SHELL	GND	-	RING WIRE	

* CGA / EGA 6PIN CONNECTION (PCB CKT NO. : CN406)

CONNECTION				REMARK
CGA SLOT	ZAMMA Spec_	WIRE COLOR	6P CONN (@ PCB)	
1 , A	H-SYNC	WHITE	6P CONN-6	
16	V-SYNC	YELLOW	6P CONN-5	
28 , f	GND & SHELL	BLACK	6P CONN-4	
T	BLUE	BLUE	6P CONN-3	
17	GREEN	GREEN	6P CONN-2	
U	RED	RED	6P CONN-1	

* CGA / EGA 5PIN CONNECTION (PCB CKT NO. : CN409)

CONNECTION				REMARK
CGA SLOT	ZAMMA Spec_	WIRE COLOR	5P CONN (@ PCB)	
1 , A	H/V COPOSITE-SYNC	WHITE	5P CONN-5	
28 , f	GND & SHELL	BLACK	5P CONN-4	
T	BLUE	BLUE	5P CONN-3	
17	GREEN	GREEN	5P CONN-2	
U	RED	RED	5P CONN-1	

2-3 TIMING CHART

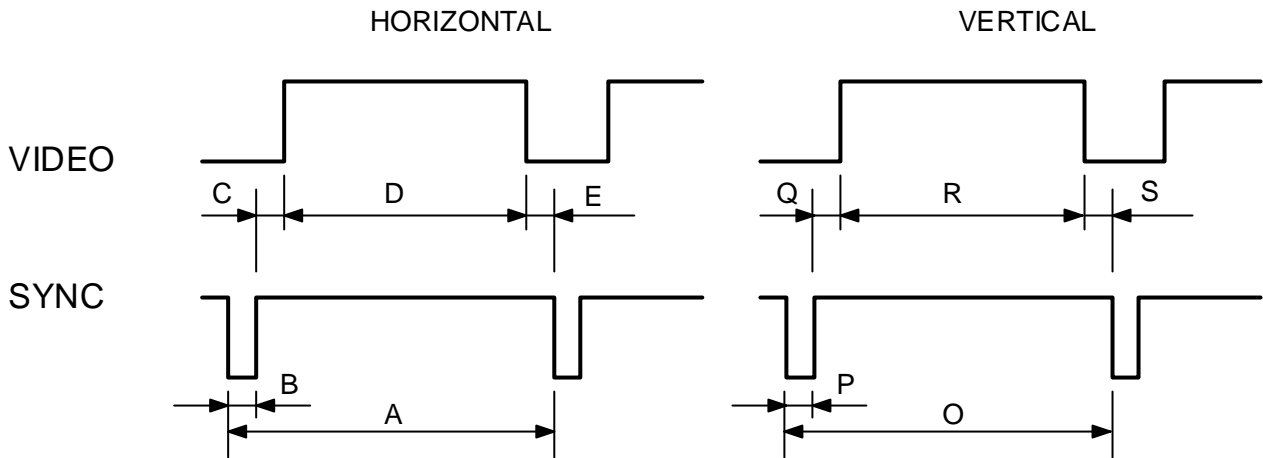

A : LINE TIME TOTAL
 C : BACK PORCH
 E : FRONT PORCH

B : HORIZONTAL SYNC WIDTH
 D : ACTIVE TIME

O : FRAME TIME TOTAL
 Q : BACK PORCH
 S : FRONT PORCH

P : VERTICAL SYNC WIDTH
 R : ACTIVE TIME

DESCRIPTION	CGA		EGA	VGA	SVGA	
	640 x 200	640 x 200	640 x 400	640*480	800*600	
H	f KHz	15.750	15.750	24.827	31.469	37.88
	A uS	63.5	63.5	40.28	31.778	26.40
	B uS	8.671	8.672	3.04	3.813	3.20
	C uS	7.272	7.272	3.8	1.907	2.20
	D uS	40.836	40.836	30.399	25.422	20.00
	E uS	6.72	6.72	3.04	0.636	1.00
	POL.	POS	POS	POS	NEG	POS
V	f Hz	50	60.115	55.609	59.940	60.317
	O mS	20.0	16.63	17.98	16.683	16.58
	P mS	0.444	0.444	0.322	0.064	0.11
	Q mS	0.825	0.825	1.26	1.048	0.61
	R mS	18.603	15.302	16.111	15.253	15.84
	S mS	0.128	0.06	0.282	0.318	0.03
	POL.	POS	POS	POS	NEG	POS

3. Operating Instruction

3-1 SET ASS'Y

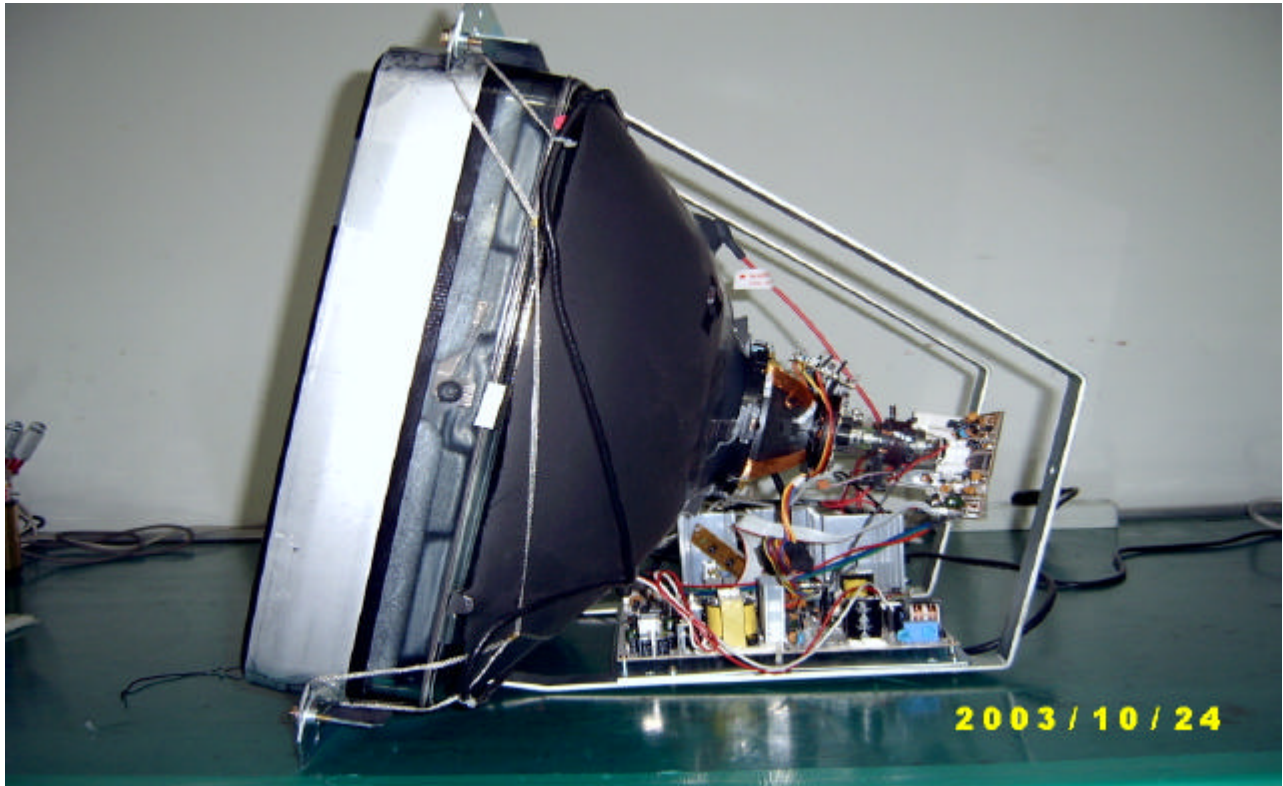

3.2 MAIN PCB ASS'Y

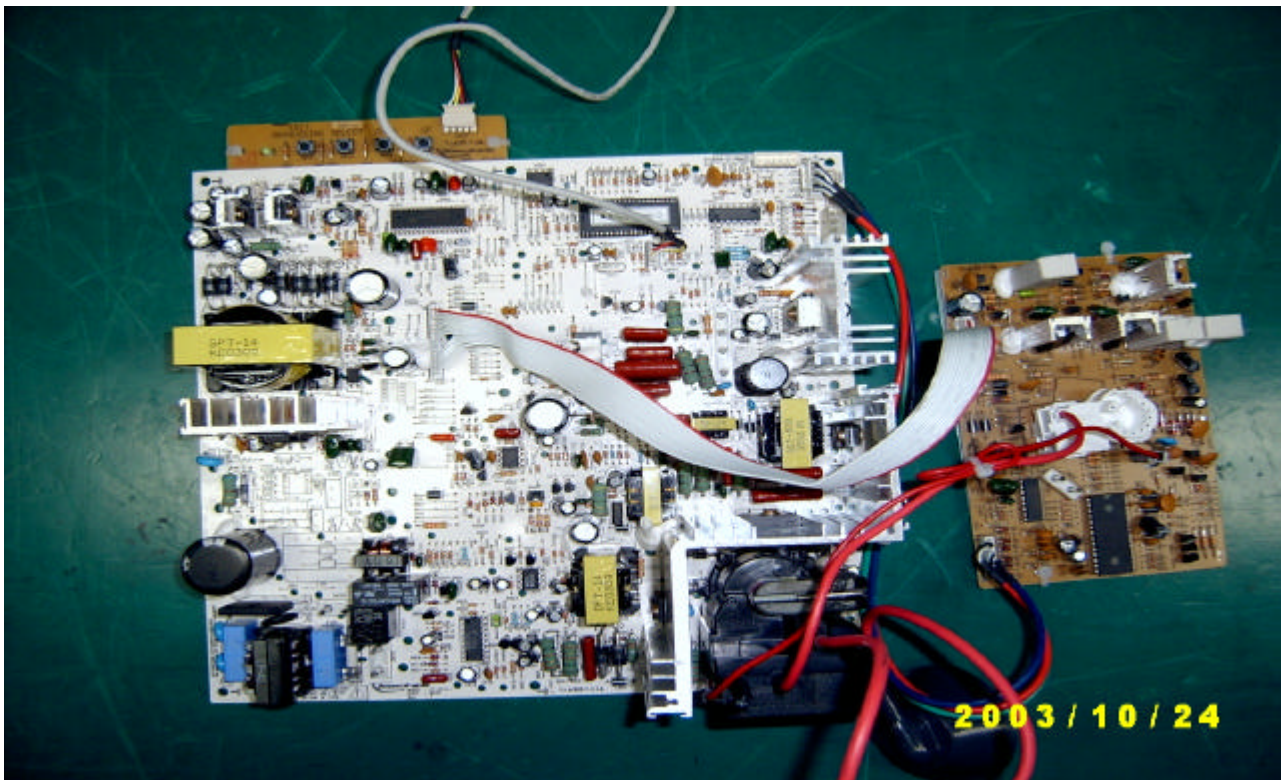

3-3. Function of Control

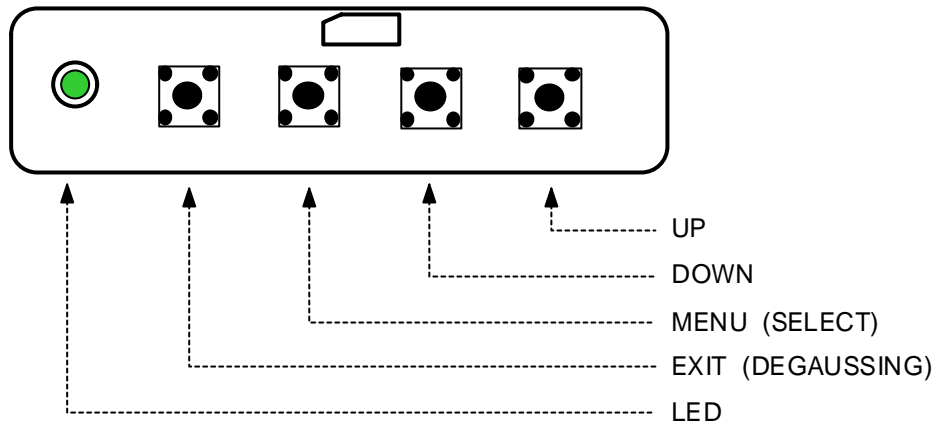

Control	Function
LED (Power Indicator)	The light of power LED changes according to each state. on mode : Green LED. power saving mode : green LED blinking.
MENU(Select)	When you press this button, the MENU appears. The MENU will disappear in 10 seconds if you don't operate any button. When you press EXIT button again, the MENU disappears. This button is used to select the control item on the MENU. In MENU, the control item could be selected and unselected by this button.
EXIT	This button is used to exit the value of any selected control.
UP	This button is used to increase the value of any selected control. This button is used to locate to the next control item for select.
DOWN	This button is used to decrease the value of any selected control. This button is used to locate to the previous control item for select.

4.Adjustments

4-1. Adjustment Control

4-1-1. Before making Adjustments

1) Orientation

When servicing, always face the monitor to east.

2) Warm-up time

The monitor must be on for 30 minutes before starting alignment. Warm-up time is especially critical in color temperature and white balance adjustments.

3) Signal

Analog, 0.714Vp-p positive at 75 Ω , internal termination.

4) High Voltage Adjustment

Signal : without signal

Adjustment : 26KV \pm 0.3KV.

PROCEDURE

Disconnect the AC line cord from the power source.

Connect positive end of High Voltage probe to anode cap of CRT, negative end of to GND(main chassis)

First of all Disconnect AC cord and than disconnect High voltage probe.

5) Screen Voltage

- signal : 640 * 480 (60Hz) , Full white

- Bright : max

- Contrast : max

- Adjustment (SAMSUNG SDI) : 550 \pm 10V

4-1-2 TURN ON THE FACTORY OSD MANUAL METHOD

1) press on the "UP" key.

2) connect the AC line cord from the power source.

3) At this time OSD menu changed factory mode.



4-2. Display Control Adjustment

Click on the "MENU" button (OSD MENU).

This menu is user's OSD manual.(user's manual)

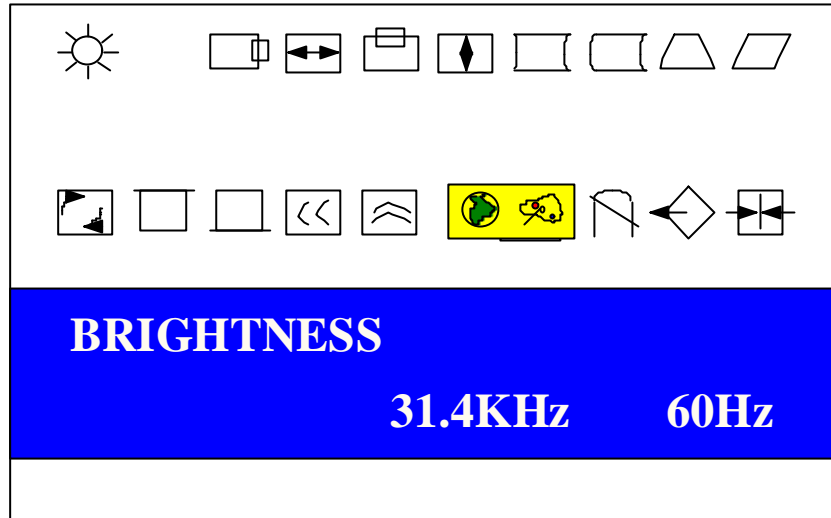

- 1) Click on the "MENU" button.
- 2) Click on the "UP" or "DOWN" and move any function control.
- 3) Press the "MENU(SELECT)" button.
- 4) "UP" or "DOWN" button is used to control the value of any function.
- 5) When you press exit button, the MENU disappears.

4-2-1 Screen center adjustment

width : 520mm height : 400mm

signal : 640 * 480 (60Hz)

| A-B | 4.0mm , | C-D | 4.0mm

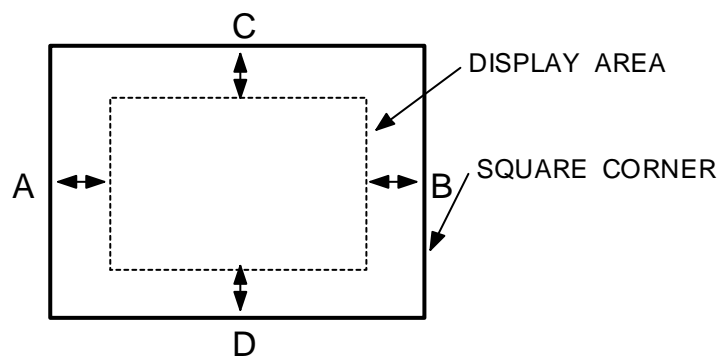

a) Horizontal size adjustment

adjustment : use to "H-SIZE", $520 \pm 3\text{mm}$

b) Vertical size adjustment

adjustment : use to "V-SIZE", $400 \pm 3\text{mm}$

c) Horizontal position adjustment

adjustment : use to "H-POS"

d) Vertical position adjustment

4-2-2 Trapezoid adjustment

frequency : all mode

signal pattern : cross hatch

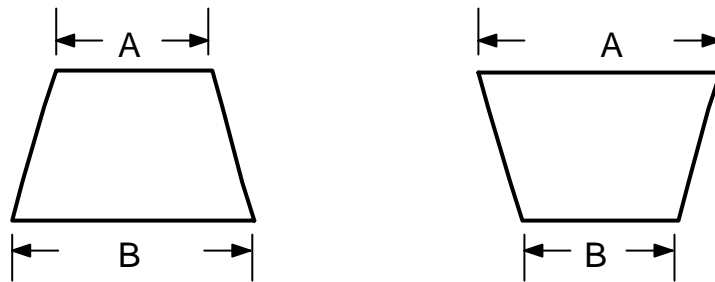

$$| A - B | < 2.5\text{mm}$$

4-2-3 Pin balance adjustment

frequency : all mode

signal pattern : cross hatch

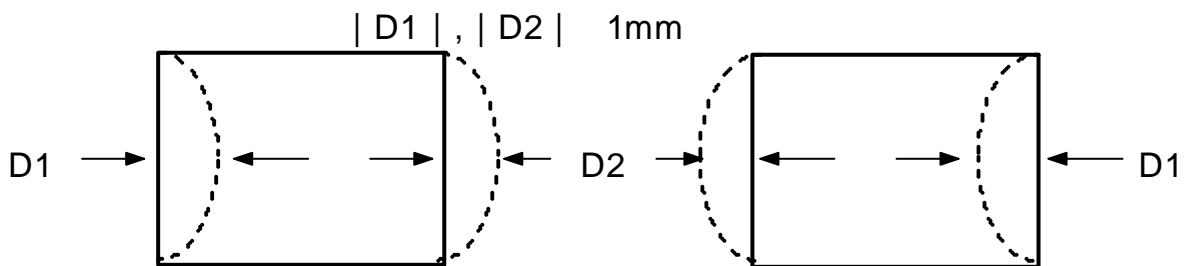

4-2-4 Parallelogram adjustment

frequency : all mode

signal pattern : cross hatch

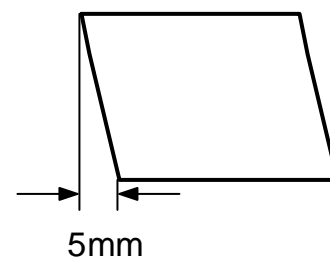

4-2-5 Side pin-cushion adjustment

frequency : all mode

signal pattern : cross hatch

brightness : MIN (cut-off)

contrast : MAX

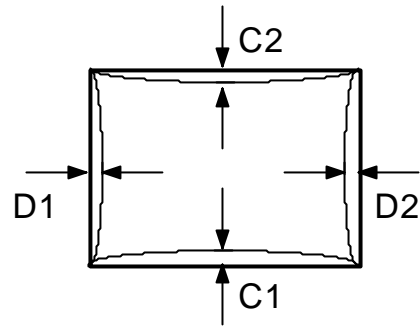

| C1 | , | C2 | 2.0mm, | D1 | , | D2 | 2.0mm

4-2-6 Tilt adjustment

frequency : all mode

signal pattern : cross hatch

brightness : MIN (cut-off)

contrast : MAX

4-2-7 Degaussing adjustment

Don't adjust the degaussing. Degaussing is possible in OSD adjustment menu. After using this function once, You must use again after at least 30minutes.

4-2-8 SAVE ADJUSTMENT CONDITION & REMOVE USER MODE.

4-3 Color adjustment

4-3-1 color temperature

Set condition

- measuring instrument : color analyzer (CA-100)
- frequency : 640 * 480 (60Hz)
- display pattern : full white , one square(20% window)
- brightness : cut off
- contrast : MAX

specification

- 9300K $x=0.281 \pm 0.02$, $y=0.311 \pm 0.02$
- 6500K $x=0.313 \pm 0.02$, $y=0.329 \pm 0.02$

4-3-2 color adjustment (9300K)

a) Back raster color adjustment

Set condition

- frequency : 640 * 480 (60Hz)
- display pattern : back raster pattern
- brightness : MIN (cut off)
- contrast : MAX

1. Select factory mode.
2. Select COLOR TEMP with UP.DOWN key.
3. Select 9300K.
4. Adjust back raster brightness to 0.01~0.02(F/L) with VR601.
5. Select B-B with UP,DOWN adjust $y=0.311$ and do the next selection with EXIT key.
6. Select R-B with UP,DOWN adjust $x=0.281$ and do the next selection with EXIT key.

a) white balance / ACL adjustment

Set condition

- frequency : 640 * 480 (60Hz)
- display pattern : one square(20% window) , full white
- brightness : MIN (cut off)
- contrast : MAX

1. Select factory mode.
2. Select COLOR TEMP with UP,DOWN key.
3. Select 9300K.
4. Select B-G with UP,DOWN adjust $y=0.311$ and do the next selection with EXIT key.
6. Select R-G with UP,DOWN adjust $x=0.281$ and do the next selection with EXIT key.
7. Select contrast icon with UP,DOWN key, adjust contrast to 50~60f/l with UP,DOWN key.

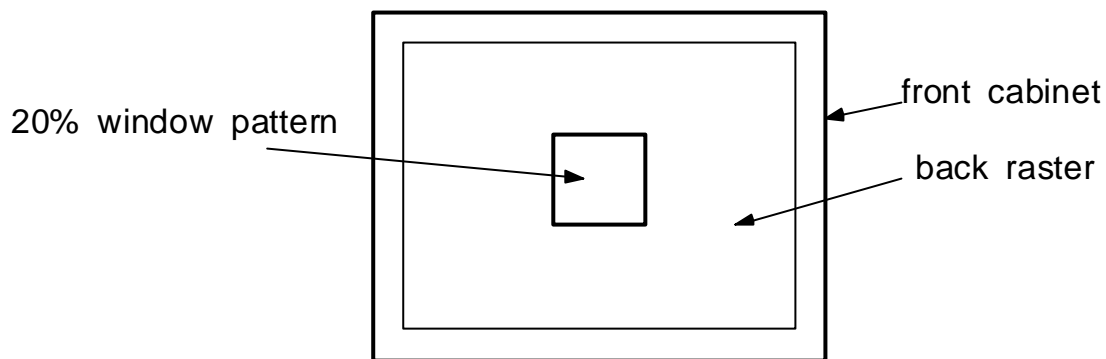

8. Select ACL key(A/C) in full white pattern and adjust ACL to 28~30f/l.

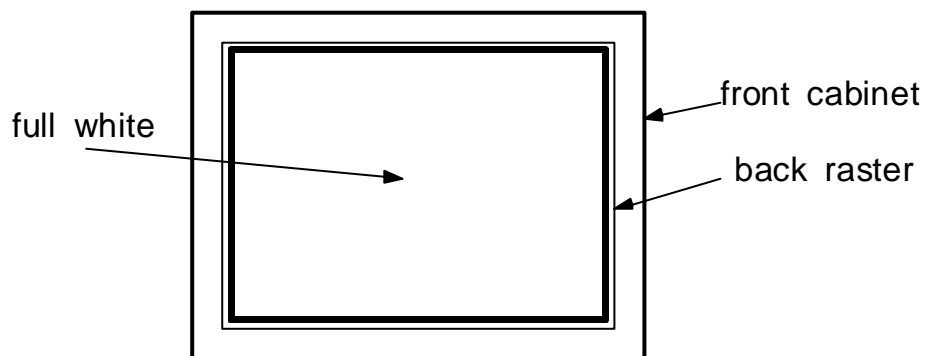

attention : If 50f/l doesn't adjust in 20% window, adjust G-G again with DOWN key.

4-3-3 color adjustment (6500K)

a) white balance adjustment

1. Select factory mode.
2. Select COLOR TEMP with UP,DOWN key.
3. Select 6500K.

4. Select B-G with UP,DOWN adjust $y=0.329$ and do the next selection with EXIT key.
6. Select R-G with UP,DOWN adjust $x=0.313$ and do the next selection with EXIT key.

4-3-4 brightness uniformity adjustment

set condition

- frequency : 640 * 480 (60Hz)
- display pattern : 9 ball pattern
- brightness : MIN (cut off)
- contrast : MAX

Measure nine brightness display in the screen.

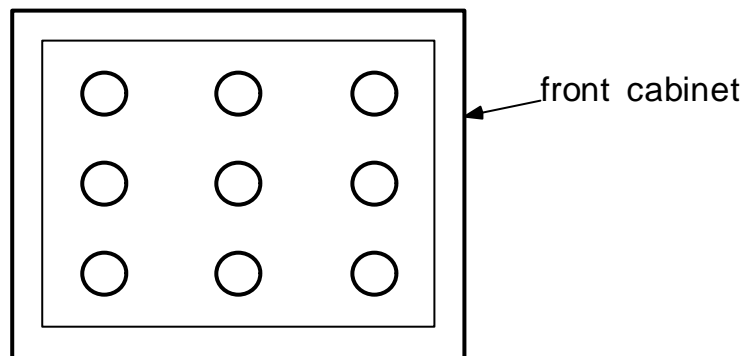

4-3-5 Focus adjustment

set condition

- frequency : 640 * 480 (60Hz)
- display pattern : "H" character
- brightness : min (cut off)
- contrast : max

1. Adjust in focus of whole screen to be the best fitted with FOCUS V/R in FBT.

4-3-6 PURITY adjustment

Purity is that unnecessary colors appear in the screen except displayed color. Don't appear unnecessary colors divided with the naked eye at a distance of 50cm from CRT surface.

set condition

- direction : east
- frequency : included timing chart
- display pattern : full white
- brightness : MIN (cut off) - display center

RED	$x=0.640 \pm 0.015$	$y=0.323 \pm 0.015$
GREEN	$x=0.295 \pm 0.015$	$y=0.594 \pm 0.015$
BLUE	$x=0.142 \pm 0.015$	$y=0.066 \pm 0.015$

5. TROUBLESHOOTING GUIDE

5-1. Troubleshooting Guide.

NOTES ;

1. If picture does not appear, fully rotate the brightness and contrast controls clockwise.
2. Check the following circuits.
 - No raster appear : power circuit. Horizontal output circuit.
 - High voltage control circuit and output circuit.
 - High voltage develops but no raster appears : Video output circuit.
 - High voltage does not develop : Horizontal output circuit.

5-2-1. No Raster, No Video

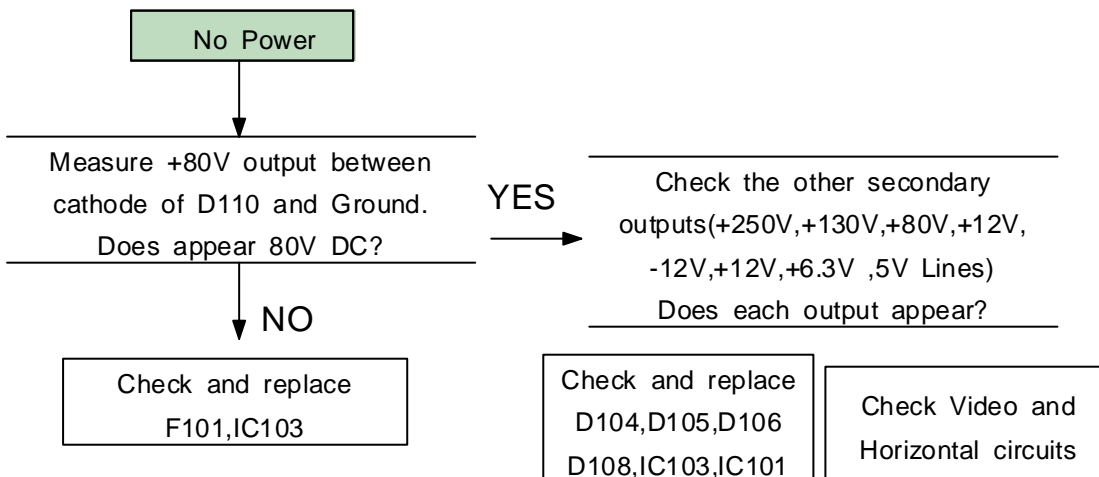

5-2-2 S-Correction failure.

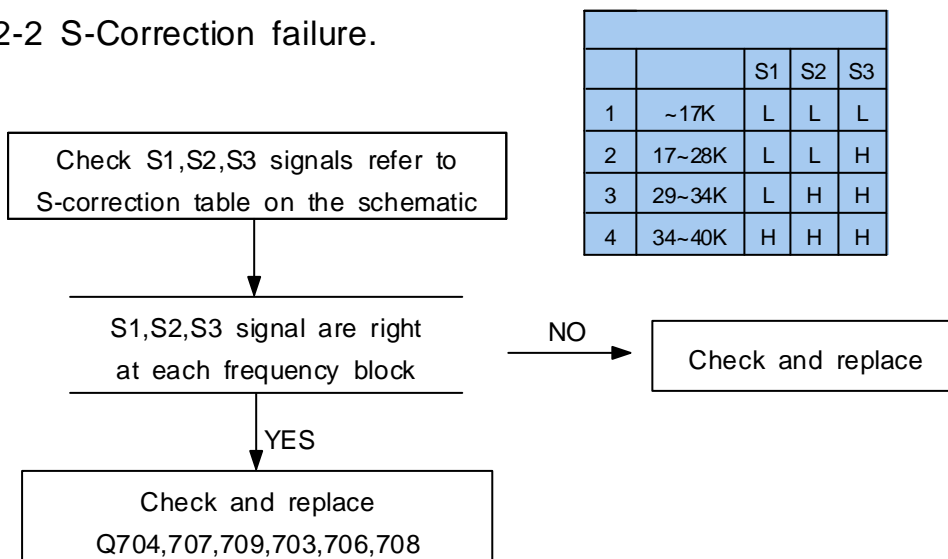

		S1	S2	S3
1	~17K	L	L	L
2	17~28K	L	L	H
3	29~34K	L	H	H
4	34~40K	H	H	H

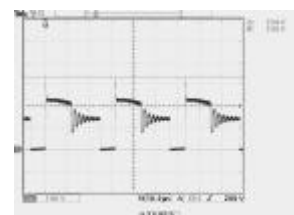

IC103 1pin

5-2-3 Degaussing failure

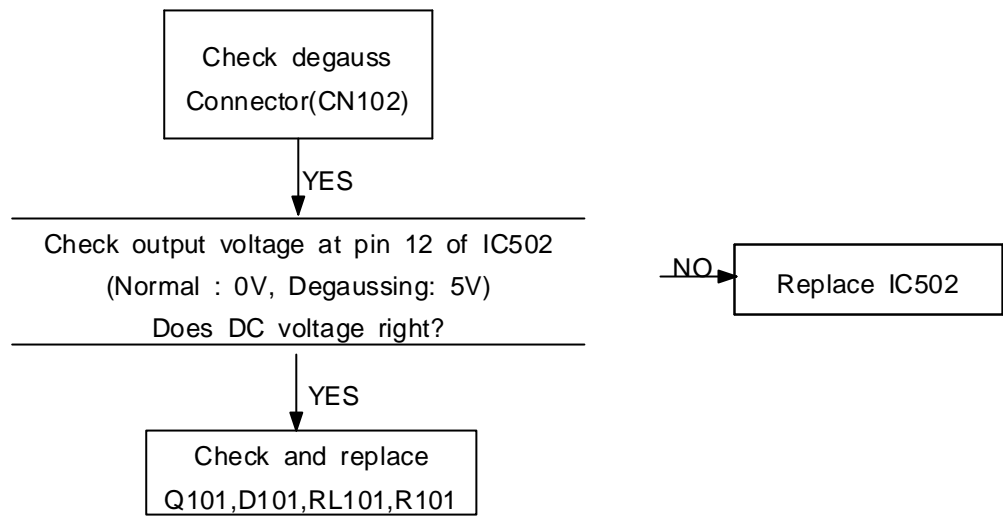

5-2-3 Purity failure

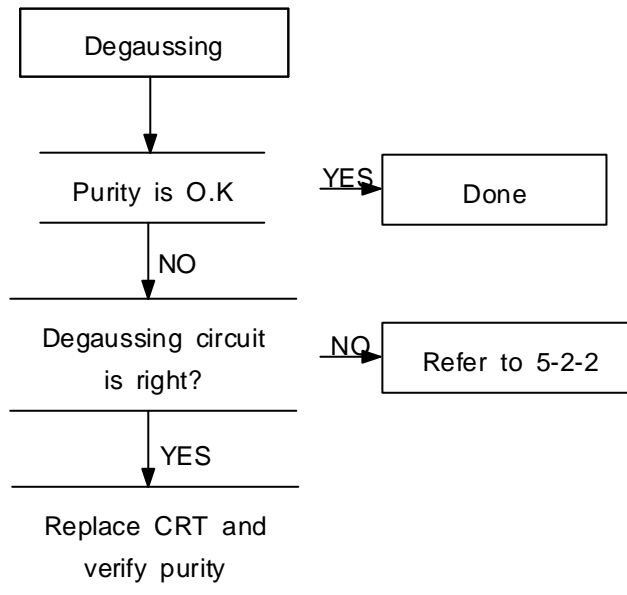

5-2-4 Rotation Failure

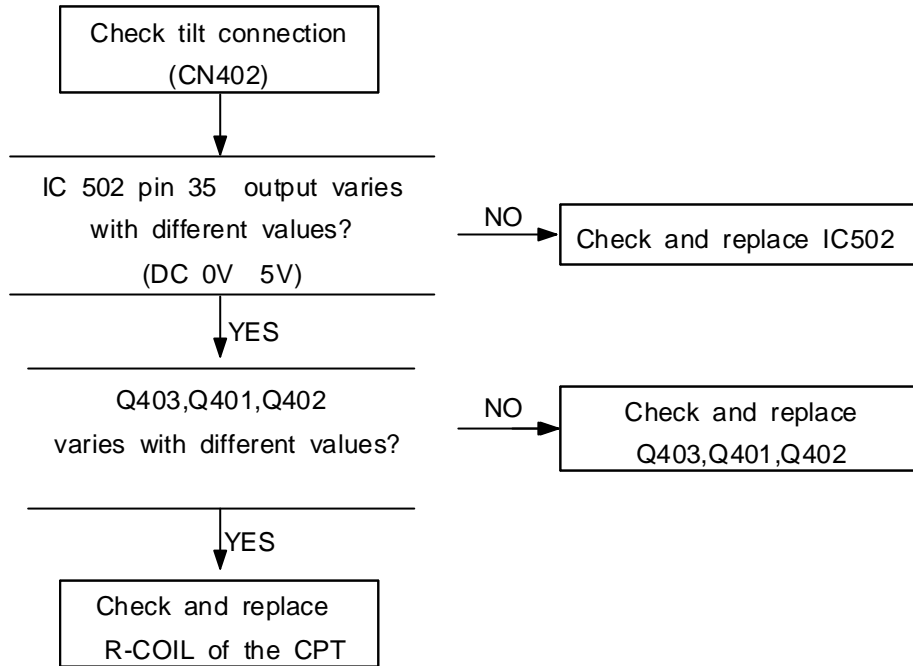

5-2-5 Misconvergence Failure

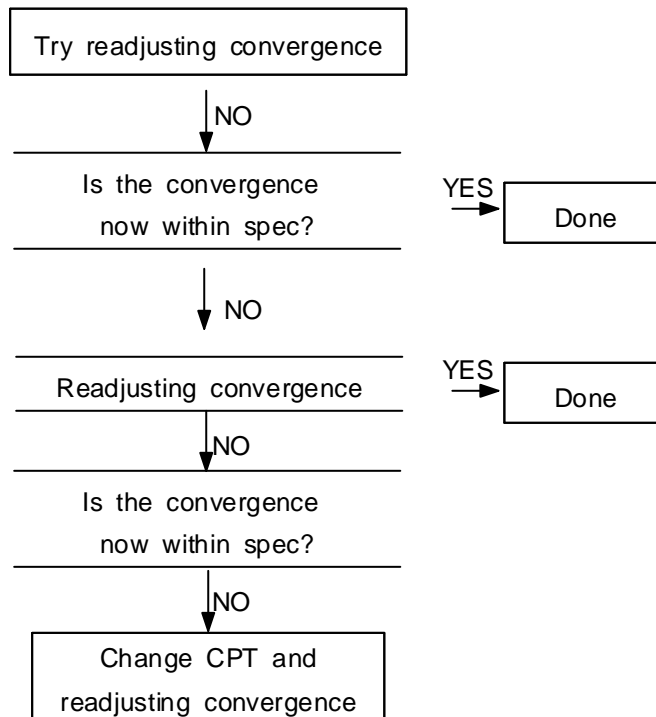

5-2-6 H-Linearity Failure

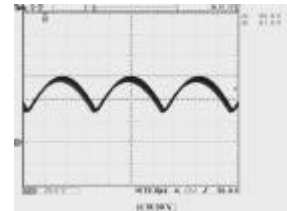
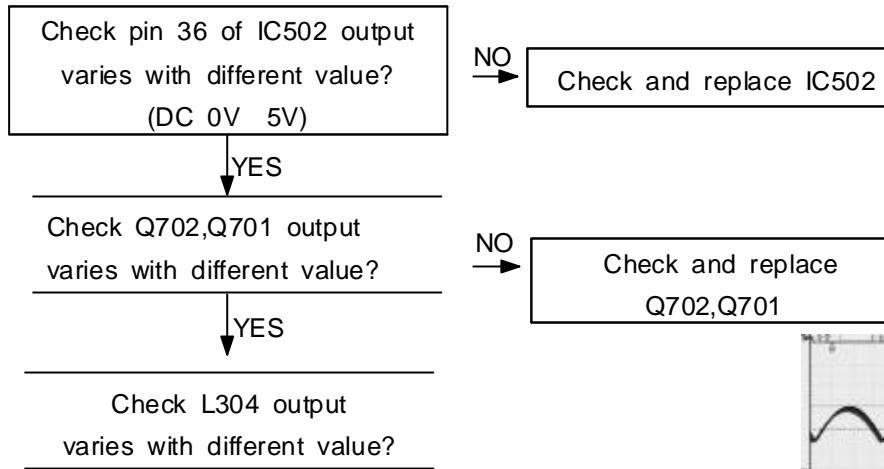

L304

5-2-7 High Voltage Failure

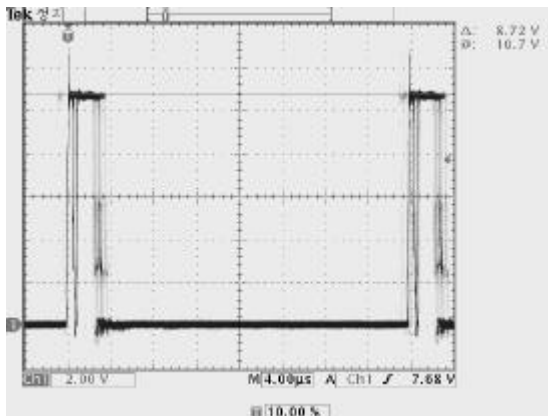
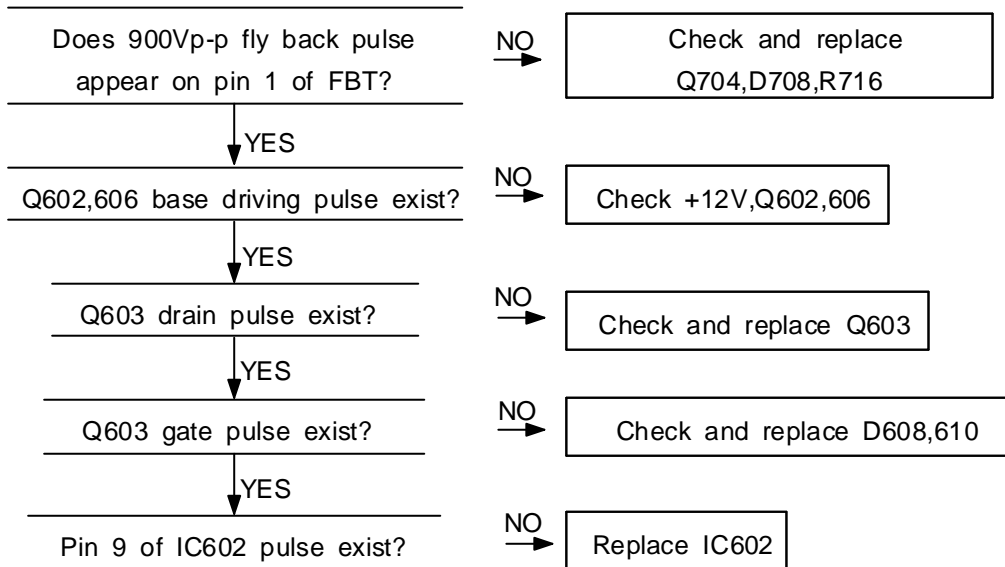

Q602,Q606 BASE

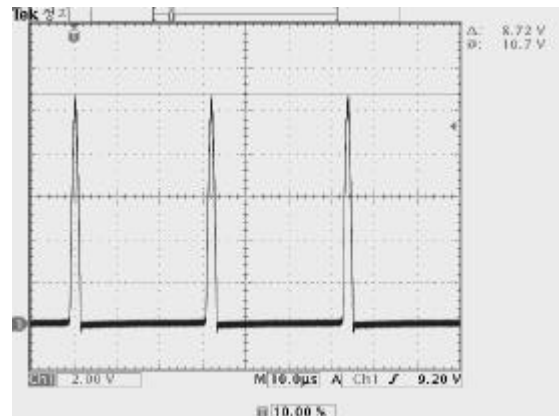

FBT 1pin

5-2-8 User control Failure

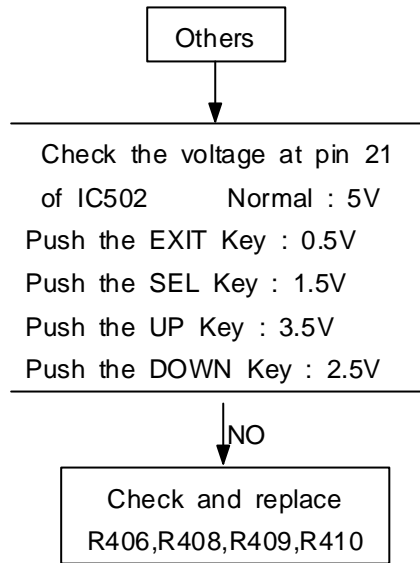

5-2-10 Dynamic Focus Failure or poor Focus

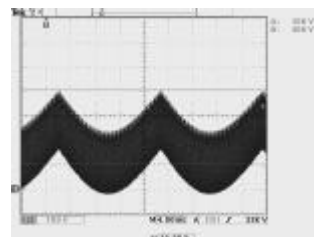
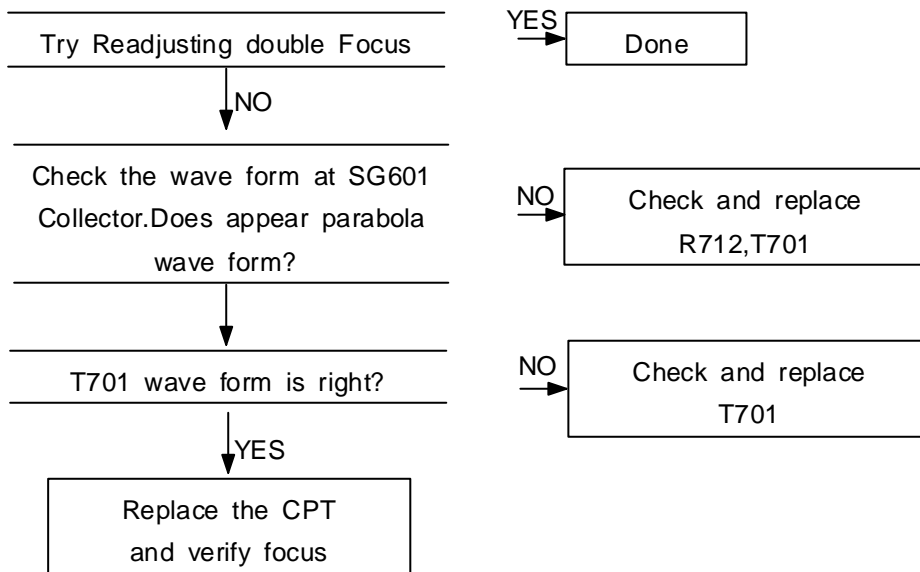

T701

5-2-10 Visible Retrace

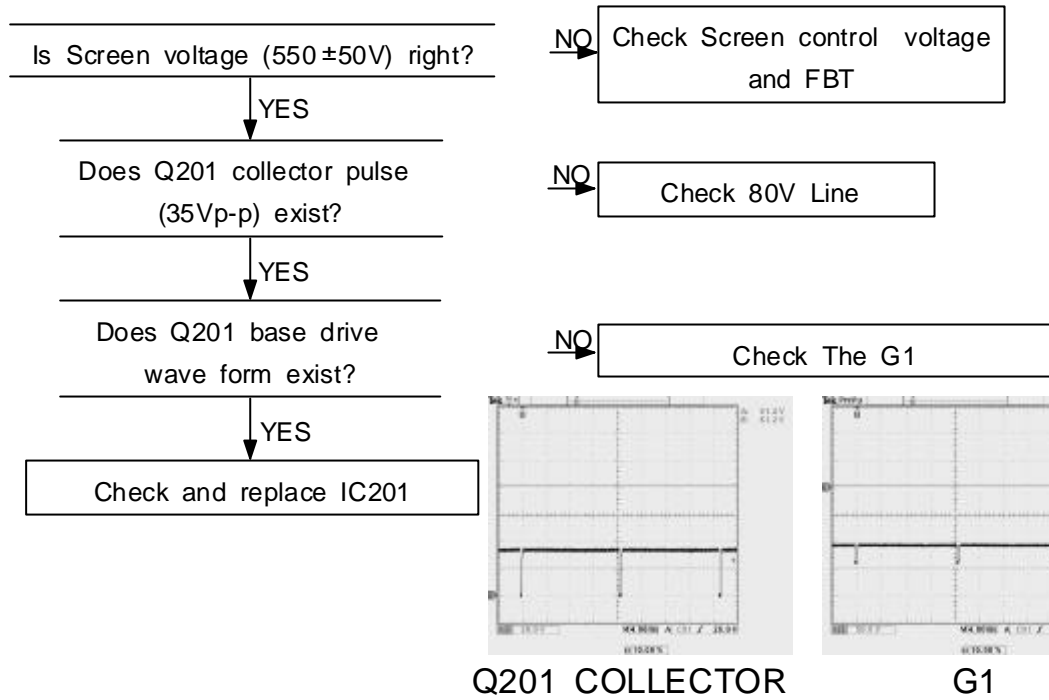

5-2-11 ACL Failure

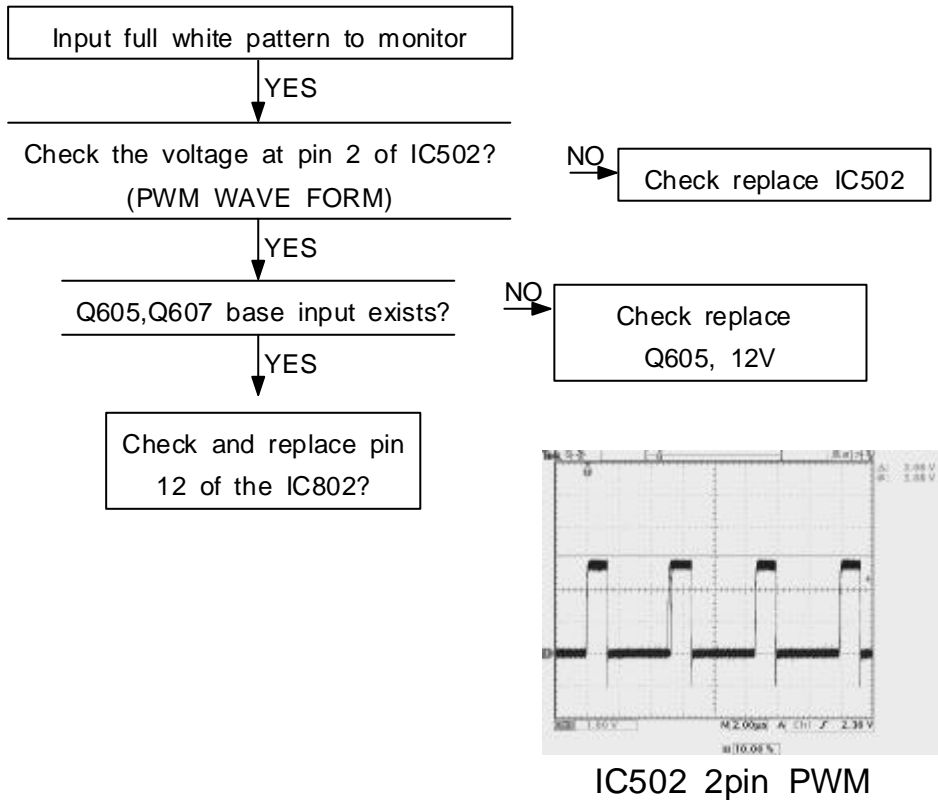

5-2-12 Micom Failure

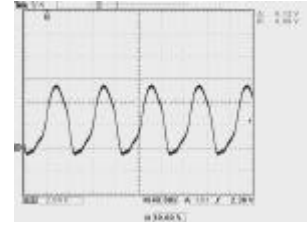
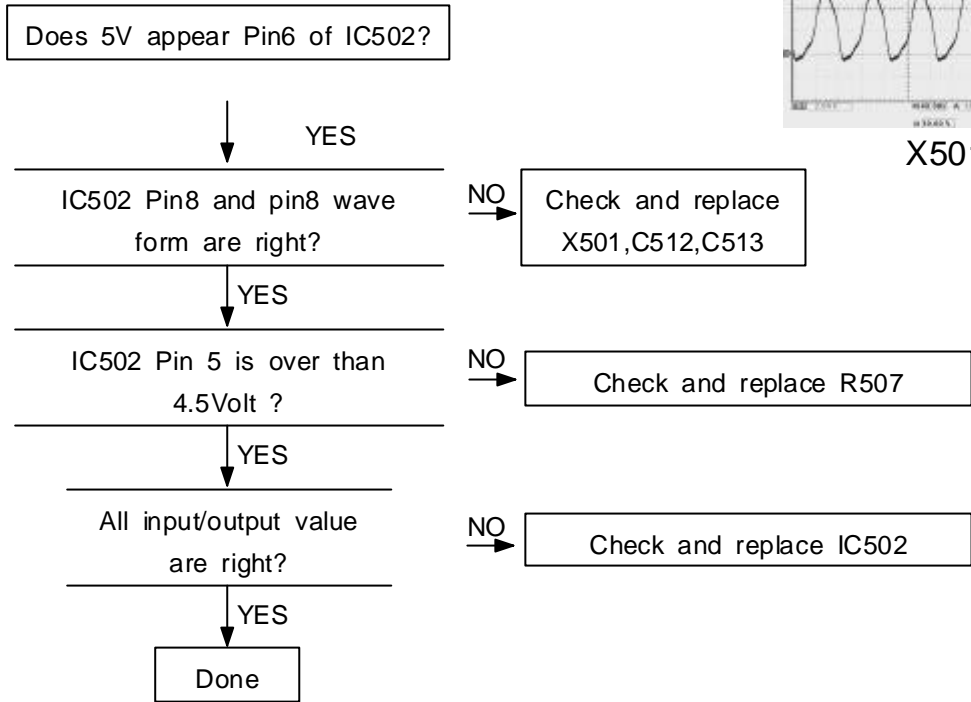

X501

5-2-13 No Raster

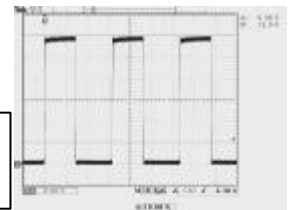
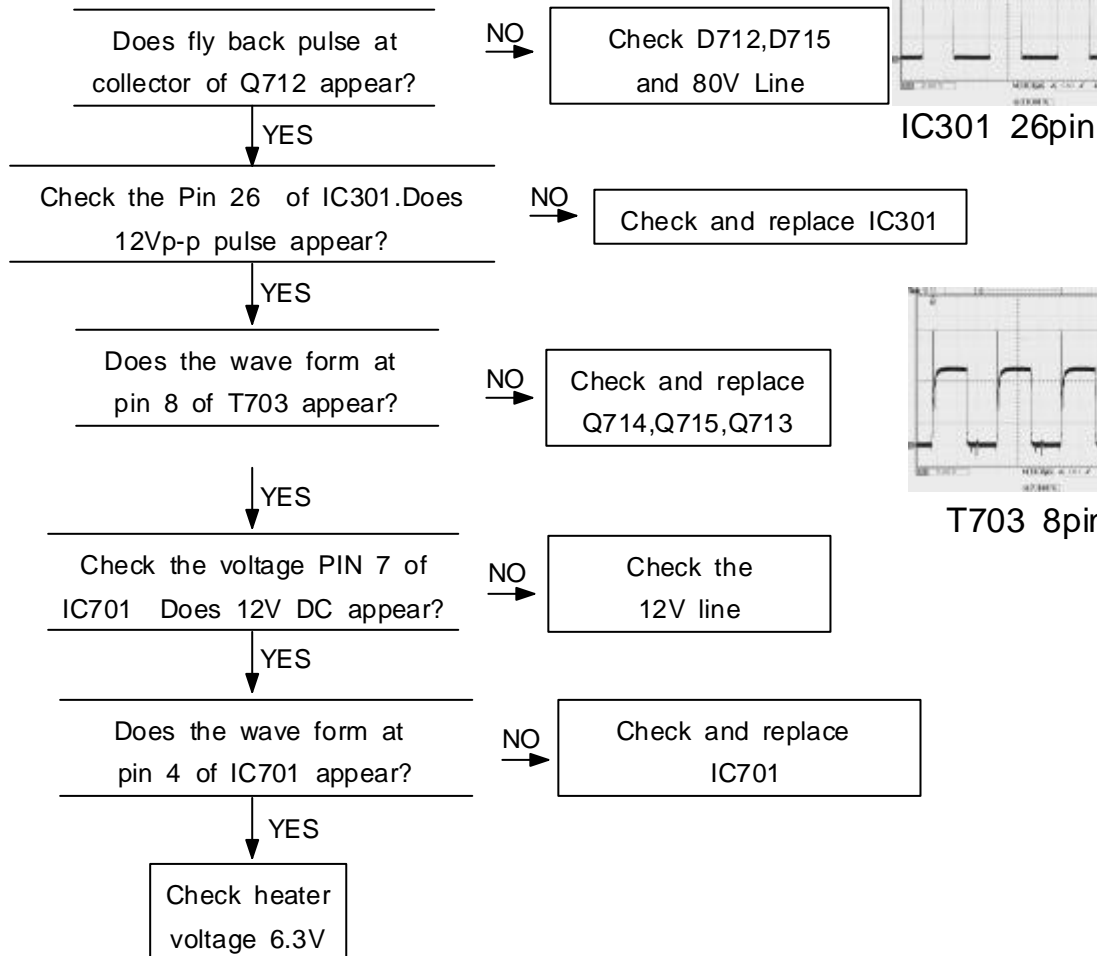

IC301 26pin

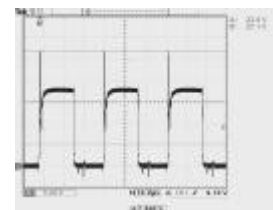

T703 8pin

5-2-14 No Video

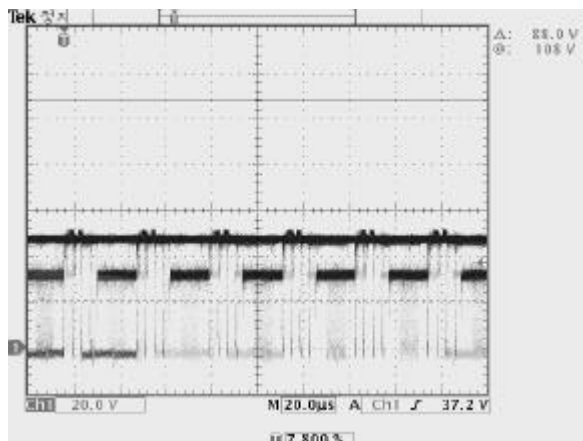
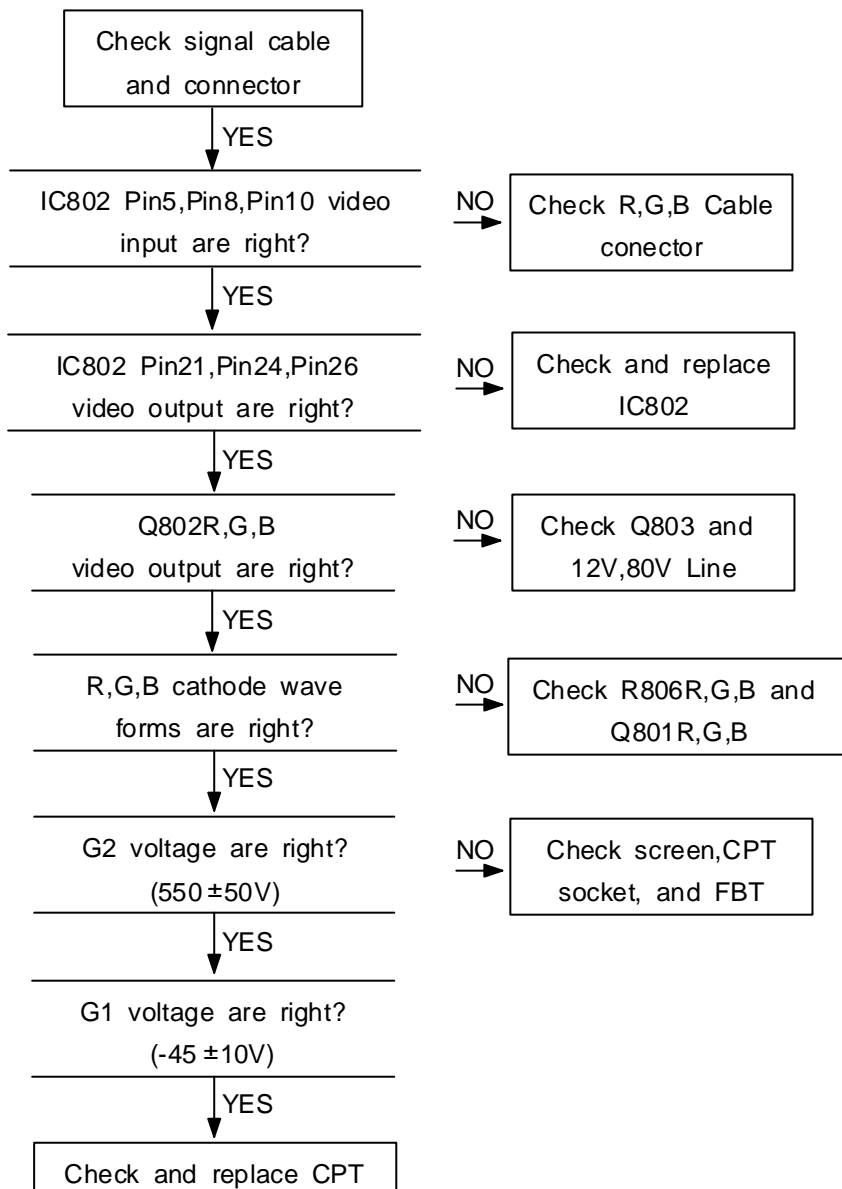

R,G,B Cathode wave form

5-2-15 Abnormal & Invariable H-size

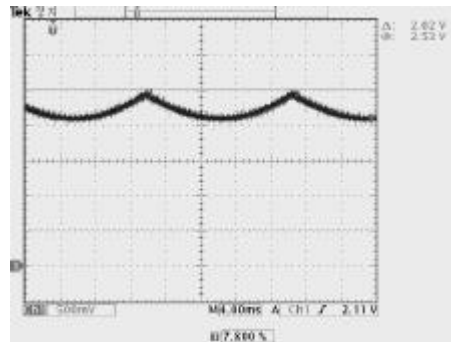
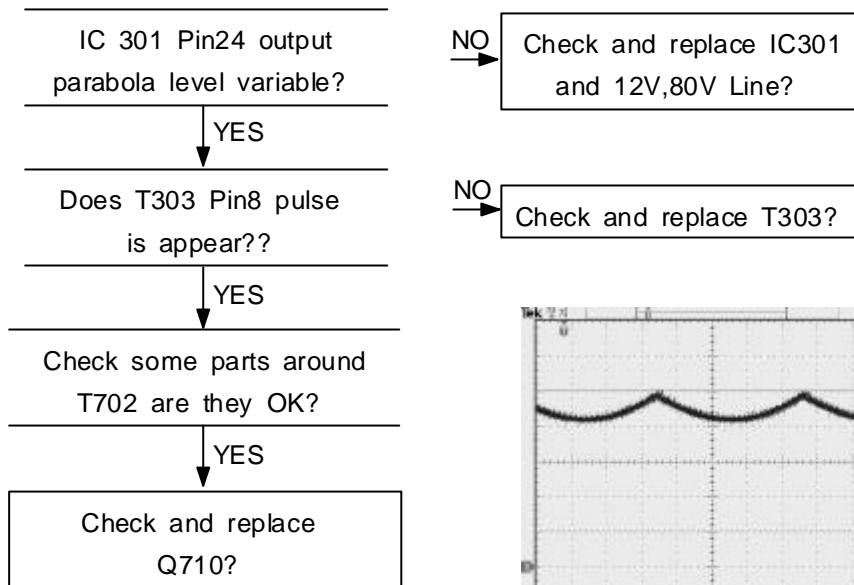

IC301 24pin

5-2-16 OSD failure

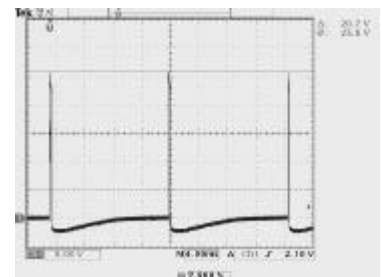
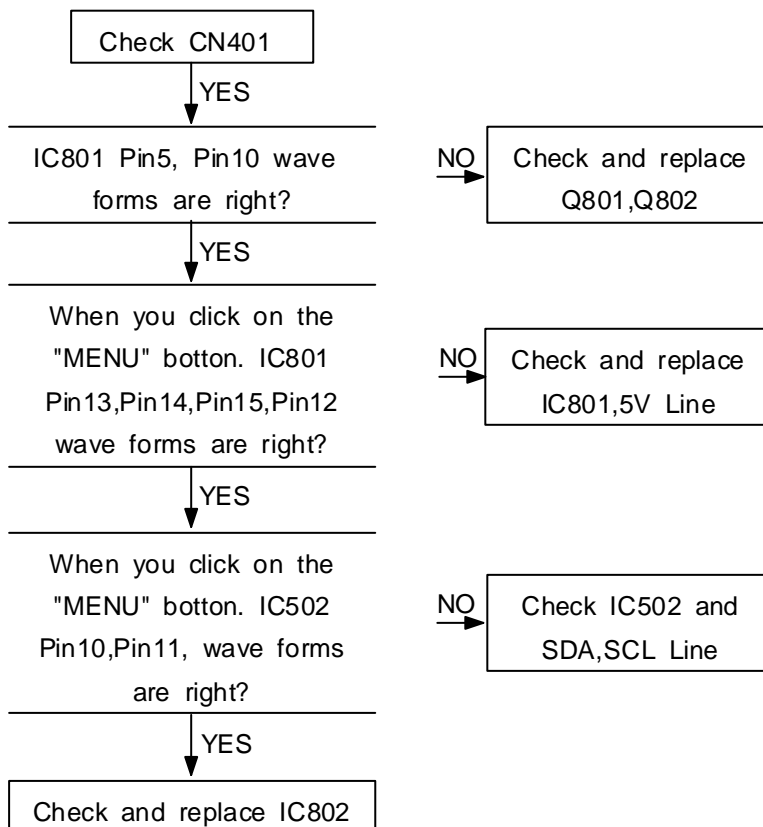

V-FLY

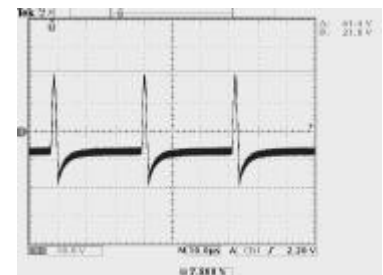

H-FLY

5-2-17 V-deflection failure

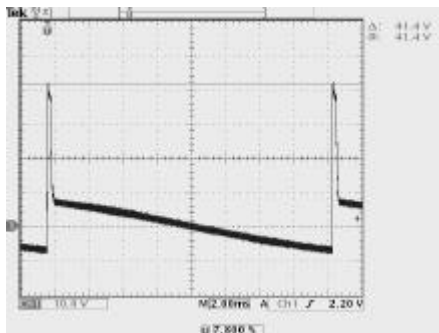
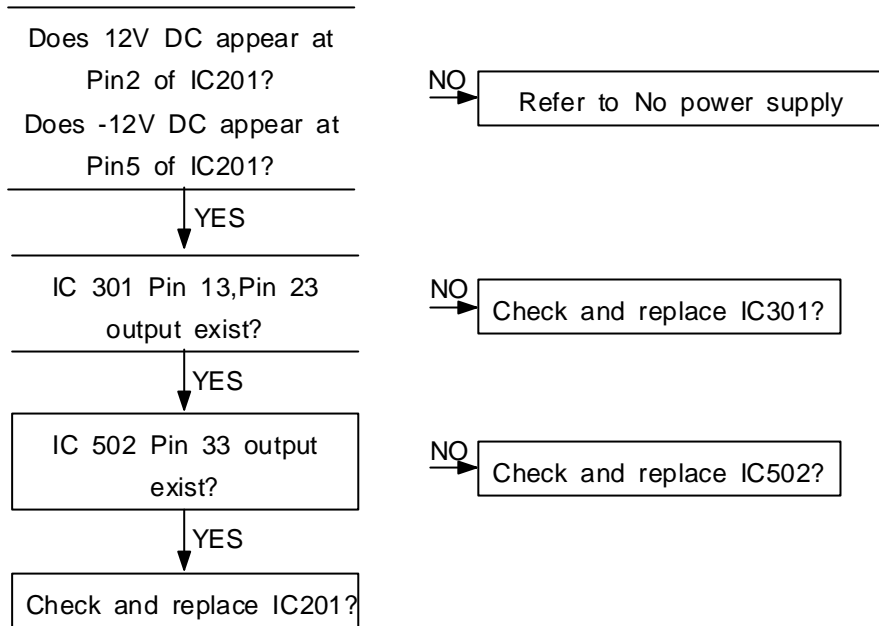

IC201 5 pin

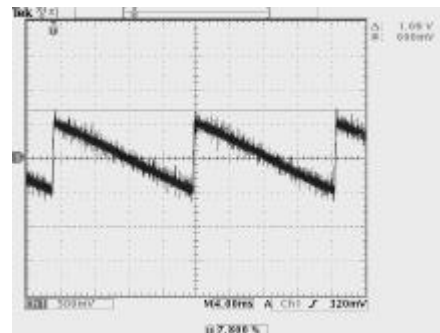

IC201 1 pin

6. PART LIST

6-1. KT-1982F PART PIST

02-291411010		MAIN PCB ASS'Y	MAIN MANUAL
1 09-131530P20	19N20	FET	1 PCS Q708
1 09-131530P21	11N40	FET	1 PCS Q710
1 11-6S1265RHA	FS6S1265-YDTU	IC-POWER	1 EA IC103
1 11-KA358AXAA	KA358A	IC-OPAMP	1 EA IC601
1 11-KA3883CAA	KA3883C	IC-PWM	1 EA IC701
1 11-KA431AZGA	KA431AZ	IC-SCR	1 EA C102
1 11-KA7500BAA	KA7500B	IC-PWM	1 EA IC602
1 11-KA7805XEA	KA7805	IC-REGULATOR	1 EA IC106
1 11-KA78R12FA	KA78R12	IC-REGULATOR	1 EA IC103
1 11-KS24C04AA	S524C80D41-DCB0	IC-I2C	1 EA IC501
1 11-LTV817BAA	LTV817-B	IC-PHOTO COUPLER	1 EA IC101
1 11-S74HC86AA	HD74HC86D/TC74HC86AP	IC	1 EA IC503
1 11-STV6888AA	STV6888 (TDA9116)	IC-TIMEBASE	1 EA IC301
1 11-TDA8172CA	TDA8172	IC	1 EA IC201
1 11-WT6291XAA	WT62P1	IC-MCU	1 EA IC502
1 21-1001R5J8A	1/2W 1.5 OHM	RES. CARBON	1 EA R210
1 21-1006R8J5A	1/4W 6.8 OHM	RES. CARBON	1 EA R618
1 21-100R47J8A	1/2W 0.47OHM	RES. CARBON	1 EA R206
1 21-101000J5A	1/4W 10 OHM	RES. CARBON	1 EA R402
1 21-101000J8A	1/2W 10 OHM	RES. CARBON	1 EA R742
1 21-101500J5A	1/4W 15 OHM	RES. CARBON	1 EA R403
1 21-104700J4A	1/6W 47 OHM	RES. CARBON	1 EA R745
1 21-104700J5A	1/4W 47 OHM	RES. CARBON	1 EA R101
1 21-107500J5A	1/4W 75 OHM	RES. CARBON	1 EA R736
1 21-112700J5A	1/4W 270 OHM	RES. CARBON	1 EA R120
1 21-113300J4A	1/6W 330 OHM	RES. CARBON	1 EA R123
1 21-115600J5A	1/4W 560 OHM	RES. CARBON	1 EA R302
1 21-117500J4A	1/6W 750 OHM	RES. CARBON	1 EA R731
1 21-120100J5A	1/4W 1 KOHM	RES. CARBON	1 EA R702
1 21-1201R8F4A	1/6W 1.8 KOHM1%	RES. METAL	1 EA R107
1 21-1201R8J5A	1/4W 1.8 KOHM	RES. CARBON	1 EA R525
1 21-1202R4J4A	1/6W 2.4 KOHM	RES. CARBON	1 EA R730
1 21-1203R9F5A	1/4W 3.9 KOHM1%	RES. METAL	1 EA R634
1 21-1203R9J4A	1/6W 3.9 KOHM	RES. CARBON	1 EA R516
1 21-1207R5J4A	1/6W 7.5 KOHM	RES. CARBON	1 EA R749
1 21-1208R2F4A	1/6W 8.2 KOHM1%	RES. METAL	1 EA R217
1 21-1209R1F4A	1/6W 9.1 KOHM1%	RES. METAL	1 EA R307
1 21-131000F5A	1/4W 10 KOHM1%	RES. METAL	1 EA R632
1 21-131500J4A	1/6W 15 KOHM	RES. CARBON	1 EA R202
1 21-132200F5A	1/4W 22 KOHM1%	RES. METAL	1 EA R728
1 21-132700F4A	1/6W 27 KOHM1%	RES. METAL	1 EA R212
1 21-133300J8A	1/2W 33 KOHM	RES. CARBON	1 EA R117
1 21-133900F4A	1/6W 39 KOHM1%	RES. METAL	1 EA R517
1 21-133900J4A	1/6W 39 KOHM	RES. CARBON	1 EA R610
1 21-141000J5A	1/4W 100 KOHM	RES. CARBON	1 EA R617
1 21-141200J8A	1/2W 120 KOHM	RES. CARBON	1 EA R111
1 21-141500J5A	1/4W 150 KOHM	RES. CARBON	1 EA R108
1 21-142000F5A	1/4W 200 KOHM1%	RES. METAL	1 EA R633
1 21-142700J5A	1/4W 270 KOHM	RES. CARBON	1 EA R615
1 21-143300J4A	1/6W 330 KOHM	RES. CARBON	1 EA R741
1 21-143300J8A	1/2W 330 KOHM	RES. CARBON	1 EA R114
1 21-143900J4A	1/6W 390 KOHM	RES. CARBON	1 EA R614
1 21-148200J4A	1/6W 820 KOHM	RES. CARBON	1 EA R127
1 21-150100J8A	1/2W 1 MOHM	RES. CARBON	1 EA R623
1 21-300100JBB	1W 1 OHM	RES. MOR	1 EA R113
1 21-300100JCB	2W 1 OHM	RES. MOR	1 EA R738
1 21-3001R2JEF	3W 1.2 OHM	RES. MOR	1 EA R748
1 21-300R33JBB	1W 0.33 OHM	RES. MOR	1 EA R619
1 21-301500JCB	2W 15 OHM	RES. MOR	1 EA R735
1 21-304700JEF	3W 47 OHM	RES. MOR	1 EA R701
1 21-308200JCB	2W 82 OHM	RES. MOR	1 EA R720
1 21-311000JEF	3W 100 OHM	RES. MOR	1 EA R715
1 21-312200JEF	3W 220 OHM	RES. MOR	1 EA R722
1 21-3206R8JEF	3W 6.8 KOHM	RES. MOR	1 EA R118
1 21-341800FBB	1W 180 KOHM1%	RES. MOR	1 EA R102
1 21-800100J8A	1/2W 1 OHM	RES. FUSEBLE	1 EA R732
1 22-630V410NT	630VT 100 KOHM T/P	RES.VARIABLE	1 EA VR601
1 23-109C0224T	63V 224K T/P (DW,OY)	MP	1 EA C733
1 23-10FA0104T	250V 104K T/P	MP	1 EA C604

1 23-24B70103B	DTN 100V 103H	CAP. METAL	1 EA C735
1 23-27B70102B	P.P,YPN 100V 102G	CAP. METAL	1 EA C305
1 23-27B70472B	P.P,YPN 100V 472G	CAP. METAL	1 EA C613
1 23-32F90154B	DTM,YMPP 250V 154J	CAP. METAL	1 EA C702
1 23-32F90224B	DTM,YMPP 250V 224J	CAP. METAL	1 EA C705
1 23-32F90274B	DTM,YMPP 250V 274J	CAP. METAL	1 EA C710
1 23-32F90564B	DTM,YMPP 250V 564J	CAP. METAL	1 EA C709
1 23-33R90102B	DTMS,YPN 1.6KV 102J	CAP. METAL	1 EA C612
1 23-34F90103B	DTN,YPN 250V 103J	CAP. METAL	1 EA C706
1 23-70B90153T	100V 153J T/P(DI,OY)	CAP. MYLAR	1 EA C102
1 23-70B90154T	100V 154J T/P	CAP. MYLAR	1 EA C309
1 23-70B90273T	100V 273J T/P	CAP. MYLAR	1 EA C729
1 23-70B90332T	100V 332J T/P	CAP. MYLAR	1 EA C717
1 23-70B90472T	100V 472J T/P	CAP. MYLAR	1 EA C208
1 26-81590121T	DC50V-SL-121UF(J)T/P	CAP. CERAMIC	1 EA C313
1 26-81590221T	DC50V-SL-221PF(J)T/P	CAP. CERAMIC	1 EA C514
1 26-81590331T	DC50V-SL-331PF(J)T/P	CAP. CERAMIC	1 EA C734
1 26-820A0102T	DC50V-B-102PF(K) T/P	CAP. CERAMIC	1 EA C506
1 26-822R0103T	DC50V-F-103PF(Z) T/P	CAP. CERAMIC	1 EA C736
1 26-P20A0101T	DC1KV-B-101PF(K) T/P	CAP. CERAMIC	1 EA C716
1 26-R20A0102T	DC2KV-B-102PF(K) T/P	CAP. CERAMIC	1 EA C714
1 27-1404022JT	SMG 400V 220 UF	CAP. ELECT. 25*40	1 EA C114
1 27-1603010FB	SMS 250V 10 UF	CAP. ELECT.	1 EA C615
1 27-16030228T	SMS 50V 22 UFT/P	CAP. ELECT.	1 EA C603
1 27-1603047DB	SMS 160V 47 UF	CAP. ELECT.	1 EA C101
1 27-16040228T	SMS 50V 220 UFT/P	CAP. ELECT.	1 EA C206
1 30-1B3906TAX	2N3906-TA	TR.	1 EA Q606
1 30-1P1271TAX	KTA1271-Y	TR.	1 EA Q402
1 30-2Z0033TAX	KSP92	TR.	1 EA Q601
1 30-3M1008TAX	KSC1008-Y	TR.	1 EA Q101
1 30-3Q3198TAX	KTC3198-Y	TR.	1 EA Q702
1 30-4F5584BNX	2SC5584	TR.	1 EA Q712
1 30-8Z0008BDX	FQP4N20	FET	1 EA Q713
1 30-8Z0027BEX	SSS10N60A	FET	1 EA Q603
1 31-100002MZX	ATS-49/U 12MHZ	CRISTAL	1 EA X501
1 33-130001901	FQM19A002	F.B.T	1 EA T601
1 33-210082004	SCT-82D (,)	TRANS.SCAN KT-2938F	1 EA T303
1 33-260082001	HDT-82 (,)	TRANS.DRIVE KT-1982	1 EA T703
1 33-312932001	60T (,)	TRANS.SYNC KT-2932	1 EA T103
1 33-340082002	GTT-82 (,)	TRANS.GATE KT-1982	1 EA T702
1 33-360014001	DFT-14 (,)	TRANS,FOCUS KT-2914	1 EA T701
1 34-160040001	LF-40 (,)	LINE FILTER KT-2938F	1 EA T102
1 34-180001002	10UH (,)	LINEARITY KT2914F	1 EA L304
1 34-22031510X	AL03 TB151K (150UH)	INDUCTORS	1 EA L301
1 34-22034700X	AL03 TB470K (47UH)	INDUCTORS	1 EA L602
1 34-250014000	SPT-14 (,)	TRANS,SMPS	1 EA T101
1 35-A1N40072T	1N4007GP	DIODE	1 EA D702
1 35-CGBU6JL1B	GBU6JL	DIODE	1 EA D120
1 35-F1N52422T	1N 5242 1/2W 12V	DIODE ZENER	1 EA D102
1 35-HDTV56F1B	DTV 56F	DIODE	1 EA D309
1 38-1013A1025	8D-13	THERMISTOR-NTC	1 EA TH102
1 38-2009A2024	2PIN-9OHM	THERMISTOR-PTC	1 EA TH101
1 38-4152A1021	1.5KV	SPARK GAP	1 EA SG601
1 39-313310000	KT-2914	MAIN PCB 247*247	1 EA MAIN PCB
1 41-HRCR71200	HR-CR7DC12V(HAN KUK)	RELAY (KT-XX82)	1 EA RL101
1 44-180101800	15P*1800mm KORTEK	SIGNAL KT-2914	1 EA SIGNAL CABLE
1 48-050405000	4P 500mm S/W	CONNECTOR KT-XX82	1 EA CN401
1 48-051303500	13P*13P*350mm	CONNECTOR KT-**82	1 EA CN411
1 49-0526702XX	5267-02	WAFER	1 EA CN402
1 49-0526706XX	5267-06	WAFER	1 EA CN404
1 49-0LW064005	LW 0640-05	WAFER LPH01-05	1 EA CN409
1 49-0LW114306	LW 1143-06	WAFER LPHP03-06	1 EA CN406
1 49-2IS42PXXX	42 PIN	IC SOCKET	1 EA IC502
1 50-21X215BDA	215 250V 3.15A	FUZE	1 EA F101
1 52-700001XXX	1 PIN (2.36)	PIN BASE	1 EA CN410
1 52-700006XXX	YFW 800-02 8 m/m	PIN BASE	1 EA CN102
1 52-700007XXX	YFW 800-02 10m/m	PIN BASE (YEON HO)	1 EA CN103
1 52-700008XXX	YFW 800-04	PIN BASE (YEON HO)	1 EA CN701
1 21-100100J8A	1/2W 1 OHM	RES. CARBON	2 EA R207,R301
1 21-1001R2F8A	1/2W 1.2 OHM 1%	RES. METAL	2 EA R215,R216

1 21- 1004R7J5A	1/4W 4.7 OHM	RES. CARBON	2 EA R116,R746
1 21- 112200J4A	1/6W 220 OHM	RES. CARBON	2 EA R507,R518
1 21- 113900J8A	1/2W 390 OHM	RES. CARBON	2 EA R126,R209
1 21- 114700J4A	1/6W 470 OHM	RES. CARBON	2 EA R532,R625
1 21- 1205R1J4A	1/6W 5.1 KOHM	RES. CARBON	2 EA R609,R630
1 21- 131000F4A	1/6W 10 KOHM1%	RES. METAL	2 EA R211,R309
1 21- 131200F4A	1/6W 12 KOHM1%	RES. METAL	2 EA R605,R727
1 21- 132200J4A	1/6W 22 KOHM	RES. CARBON	2 EA R201,R631
1 21- 137500J4A	1/6W 75 KOHM	RES. CARBON	2 EA R740,R750
1 21- 141000J8A	1/2W 100 KOHM	RES. CARBON	2 EA R110,R726
1 21- 142000J8A	1/2W 200 KOHM	RES. CARBON	2 EA R112,R115
1 21- 142200J4A	1/6W 220 KOHM	RES. CARBON	2 EA R105,R404
1 21- 142200J8A	1/2W 220 KOHM	RES. CARBON	2 EA R121,R122
1 21- 802200J8A	1/2W 22 OHM	RES. FUSEBLE	2 EA R733,R752
1 23- 33R90472B	DTMS,YPN 1.6KV 472J	CAP. METAL	2 EA C727,C728
1 23- 39G90224X	BOX AC 275V 224UF	CAP. BOX(PILKOR)	2 EA C111,C120
1 23- 70B90222T	100V 222J T/P	CAP. MYLAR	2 EA C131,C737
1 23- 70B90223T	100V 223J T/P	CAP. MYLAR	2 EA C108,C722
1 23- 70B90224T	100V 224J T/P	CAP. MYLAR	2 EA C106,C207
1 23- 70B90563T	100V 563J T/P	CAP. MYLAR	2 EA C306,C609
1 26- 81590022T	DC50V-SL-22PF(J) T/P	CAP. CERAMIC	2 EA C512,C513
1 26- 81590101T	DC50V-SL-101PF(J)T/P	CAP. CERAMIC	2 EA C507,C516
1 26- 81590681T	DC50V-SL-681PF(J)T/P	CAP. CERAMIC	2 EA C515,C726
1 27- 10050103B	SR 16V 1000 UF	CAP. ELECT. 12.5*16	2 EA C112,C113
1 27- 1203047HB	SHL 350V 47 UF	CAP. ELECT. 16*25	2 EA C130,C711
1 27- 1204010BB	SHL 100V 100 UF	CAP. ELECT. 10*20	2 EA C126,C602
1 27- 16030473T	SMS 16V 47 UFT/P	CAP. ELECT. 5*11	2 EA C508,C607
1 30- 1J0733TAX	KSA733C-Y	TR.	2 EA Q711,Q715
1 30- 8Z0007BDX	FQP19N20	FET	2 EA Q703,Q706
1 35- ABAV21X2T	BAV21	DIODE	2 EA D605,D704
1 35- BMUR4601T	GUR460	DIODE	2 EA D608,D610
1 35- BUF1GXX1T	UF-1G	DIODE	2 EA D108,D707
1 35- BUF54042T	UF5404GI	DIODE	2 EA D105,D106
1 35- F1N52302T	1N 5230 1/2W 4.7V	DIODE ZENER	2 EA D103,D601
1 35- F1N52322T	1N 5232 1/2W 5.6V	DIODE ZENER	2 EA D403,D404
1 49- 0SMMV25006	SMW 250-06	WAFER	2 EA CN405,CN407
1 52- 300002XXX	FC-51F KT-1970/1982	FUSE CLIP TAPING	2 EA F101
1 21- 111200J4A	1/6W 120 OHM	RES. CARBON	3 EA R801,R816,R817
1 21- 1201R5J4A	1/6W 1.5 KOHM	RES. CARBON	3 EA R109,R611,R703
1 21- 1208R2J4A	1/6W 8.2 KOHM	RES. CARBON	3 EA R205,R401,R705
1 21- 141000J4A	1/6W 100 KOHM	RES. CARBON	3 EA R709,R718,R724
1 21- 331000JEF	3W 10 KOHM	RES. MOR	3 EA R626,R627,R712
1 23- 70B90473T	100V 473J T/P	CAP. MYLAR	3 EA C712,C725,C502
1 26- F21C0222B	DS250V-E-222PF(M)	CAP. CERAMIC	3 EA C109,C110,C129
1 26- M20A0102T	DC500V-B-102PF(K)T/P	CAP. CERAMIC	3 EA C707,C713,C731
1 26- M22R0103T	DC500V-F-103PF(Z)T/P	CAP. CERAMIC	3 EA C103,C116,C715
1 26- R20A0221T	DC2KV-B-221PF(K) T/P	CAP. CERAMIC	3 EA C121,C610,C704
1 27- 16030338T	SMS 50V 33 UFT/P	CAP. ELECT. 5*11	3 EA C123,C617,C724
1 27- 16040223T	SMS 16V 220 UFT/P	CAP. ELECT. 8*11.5	3 EA C138,C614,C730
1 27- 41023R38T	SMBP 50V 3.3 UF T/P	CAP. ELECT. 5*11	3 EA C307,C620,C622
1 30- 3Q3203TAX	KTC3203-Y	TR.	3 EA Q401,Q403,Q701
1 21- 1202R2J4A	1/6W 2.2 KOHM	RES. CARBON	4 EA R513,R530,R602,R607
1 21- 1202R7J4A	1/6W 2.7 KOHM	RES. CARBON	4 EA R310,R311,R312,R629
1 21- 1205R6J4A	1/6W 5.6 KOHM	RES. CARBON	4 EA R601,R604,R612,R734
1 21- 134700J4A	1/6W 47 KOHM	RES. CARBON	4 EA R533,R536,R729,R214
1 23- 109A0474T	63V 474K T/P (DW,OY)	MP	4 EA C308,C311,C718,C720
1 23- 70B90103T	100V 103J T/P(DI,OY)	CAP. MYLAR	4 EA C105,C107,C303,C719
1 30- 3B3904TAX	2N3904-TA	TR.	4 EA Q602,Q604,Q605,Q607
1 35- B31GF6X1B	31GF6	DIODE	4 EA D110,D112,D113,D121
1 21- 131800J4A	1/6W 18 KOHM	RES. CARBON	5 EA R706,R716,R721,R739,R751
1 26- 81590033T	DC50V-SL-33PF(J) T/P	CAP. CERAMIC	5 EA C403,C404,C405,C504,C505
1 27- 16024R78T	SMS 50V 4.7 UFT/P	CAP. ELECT. 5*11	5 EA C209,C302,C312,C401,C621
1 27- 16030108T	SMS 50V 10 UFT/P	CAP. ELECT. 5*11	5 EA C501,C503,C509,C601,C721
1 35- BUF40072T	UF4007GI	DIODE	5 EA D107,D111,D614,D615,D616
1 21- 1206R8J4A	1/6W 6.8 KOHM	RES. CARBON	6 EA R106,R213,R308,R621,R737,R747
1 21- 131000J4A	1/6W 10 KOHM	RES. CARBON	6 EA R103,R305,R503,R506,R620,D301
1 23- 70B90104T	100V 104J T/P(DI,OY)	CAP. MYLAR	6 EA C127,C128,C301,C402,C517,C619
1 26- 822R0104T	DC50V-F-104PF(Z) T/P	CAP. CERAMIC	6 EA C122,C204,C406,C606,C616,C732
1 27- 12040473T	SHL 16V 470 UFT/P	CAP. ELECT. 8*11.5	6 EA C118,C119,C135,C203,C205,C304
1 30- 3M0945TAX	KSC945C-Y	TR.	6 EA Q103,Q201,Q704,Q707,Q709,Q714

1 21- 1201R2J4A	1/6W 1.2 KOHM	RES. CARBON	7 EA	R306,R708,R710,R717,R719,R723,R725
1 35- BUFA40041T	UF4004GI	DIODE	7 EA	D104,D109,D202,D612,D703,D711,D715
1 27- 16020018T	SMS 50V 1 UFT/P	CAP. ELECT. 5*11	8 EA	C125,C201,C310,C608,C618,C701,C708,C723 R104,R505,R514,R515,R537,R608,R613,R616,
1 21- 120100J4A	1/6W 1 KOHM	RES. CARBON	10 EA	R622,R624
1 34- 413550001	ATS3550L(3.5X5mm)	BEAD CORE	12 EA	L101,L103,L104,L105,L107,L601,L604,L605,L7 02,L703,L704,L705
1 21- 1204R7J4A	1/6W 4.7 KOHM	RES. CARBON	14 EA	R129,R204,R208,R501,R502,R504,R508,R509, R510,R511,R512,R519,R603,R628
1 21- 111000J4A	1/6W 100 OHM	RES. CARBON	18 EA	R303,R304,R411-R413,R417-R419,R521-R524, R526,R529,R531,R534,R535,R744
1 35- E1N41482T	1N 4148	DIODE	19 EA	D101,D114,D115,D401,D602-D604,D606,D607,D611,D613,D6 17,D701,D705,D706,D708-D710,D714
1 43- 880052R0T	52 mm TAPING	JUMP WIRE	## EA	R131,D116,J001~J128
05- 112914010		V- MANUAL ASS'Y	PCS	
2 11- KA2506XAA	KA2506	IC- PREAMP	1 EA	IC802
2 11- WT6802XAA	WT6802	IC- OSD	1 EA	IC801
2 21- 112200J8A	1/2W 220 OHM	RES. CARBON	1 EA	R830
2 21- 1203R9J4A	1/6W 3.9 KOHM	RES. CARBON	1 EA	R812
2 21- 131000J4A	1/6W 10 KOHM	RES. CARBON	1 EA	R803
2 21- 131800J4A	1/6W 18 KOHM	RES. CARBON	1 EA	R831
2 23- 70B90224T	100V 224J T/P	CAP. MYLAR	1 EA	C808
2 23- 70B90472T	100V 472J T/P	CAP. MYLAR	1 EA	C805
2 26- R20A0102T	DC2KV-B-102PF(K) T/P	CAP. CERAMIC	1 EA	C816
2 27- 16023R38T	SMS 50V 3.3 UFT/P	CAP. ELECT. 5*11	1 EA	C834
2 27- 1603010DT	SMS 160V 10 UFT/P	CAP. ELECT. 10*16	1 EA	C804
2 27- 16040103T	SMS 16V 100 UFT/P	CAP. ELECT. 6.3*11	1 EA	C801
2 38- 3400M1021	WSP 401M	SURGE ABSORBER	1 EA	SG803
2 38- 4152A1021	1.5KV	SPARK GAP	1 EA	SG802
2 39- 111820000	KT-2914	VIDEO PCB	1 EA	VIDEO PCB
2 48- 040603304	6P*6P*380mm RGB	CONNECTOR,KT-2914	1 EA	CONNECTOR,KT-2914
2 49- 0SMW25013	SMM 250-13	WAFER	1 EA	CN801
2 49- 162601XXX	PCS 626-01	CRT SOCKET	1 EA	CRT801
2 52- 700001XXX	1 PIN (2.36)	KT-XX03V	1 EA	CN803
2 52- 700006XXX	YFW 800-02 8 m/m	PIN BASE	1 EA	CN806
2 21- 116800J4A	1/6W 680 OHM	RES. CARBON	2 EA	R808,R815
2 26- 81090101T	DC50V-CH-101PF(JT)/P	CAP. CERAMIC	2 EA	C806,C807
2 27- 16040223T	SMS 16V 220 UFT/P	CAP. ELECT. 8*11.5	2 EA	C810,C823
2 30- 3B3904TAX	2N3904-TA	TR.	2 EA	Q801,Q802
2 09- 121540P20	C3503-D	H/S ASS'Y	3 PCS	Q803R,Q803G,Q803B
2 21- 111000J8A	1/2W 100 OHM	RES. CARBON	3 EA	R806R,R806G,R806B
2 21- 112200J4A	1/6W 220 OHM	RES. CARBON	3 EA	R808R,R808G,R808B
2 21- 120100J4A	1/6W 1 KOHM	RES. CARBON	3 EA	R802,R805,R806
2 21- 1203R3J4A	1/6W 3.3 KOHM	RES. CARBON	3 EA	R811R,R811G,R811B
2 21- 1204R7J4A	1/6W 4.7 KOHM	RES. CARBON	3 EA	R804R,R804G,R804B
2 21- 135600J4A	1/6W 56 KOHM	RES. CARBON	3 EA	R809R,R809G,R809B
2 21- 136800J5A	1/4W 68 KOHM	RES. CARBON	3 EA	R810R,R810G,R810B
2 21- 141000J4A	1/6W 100 KOHM	RES. CARBON	3 EA	R802R,R802G,R802B
2 21- 143300J4A	1/6W 330 KOHM	RES. CARBON	3 EA	R803R,R803G,R803B
2 21- 9201R5FJW	7W 1.5 KOHM 1%	RES. CEMENT	3 EA	R801R,R801G,R801B
2 23- 70B90104T	100V 104J T/P(DI,OY)	CAP. MYLAR	3 EA	C802R,C802G,C802B
2 26- 81090010T	DC50V-CH-10D(J) T/P	CAP. CERAMIC	3 EA	C803R,C803G,C803B
2 26- 81590033T	DC50V-SL-33PF(J) T/P	CAP. CERAMIC	3 EA	C805R,C805G,C805B
2 27- 4102001BT	SMBP 100V 1 UF T/P	CAP. ELECT. 5*11	3 EA	C801R,C801G,C801B
2 30- 3Z0030TAX	KSP2222A	TR.	3 EA	Q805R,Q805G,Q805B
2 34- 22031R20X	AL03 TB1R2K (1.2UH)	INDUCTORS	3 EA	L801R,L801G,L801B
2 35- ABAV21X2T	BAV21	DIODE	3 EA	D805R,D805G,D805B
2 35- F1N52402T	1N 5240 1/2W 10V	DIODE ZENER	3 EA	D804R,D804G,D804B
2 38- 3200M1021	WSA 201M	SUREG ABSORBER	3 EA	SG801R,SG801G,SG801B
2 35- E1N49371T	1N 4937	DIODE	4 EA	D801R,D801G,D801B,D812
2 26- M22R0103T	DC500V-F-103PF(Z)T/P	CAP. CERAMIC	5 EA	C804R,C804G,C804B,C809,C820
2 21- 106800J5A	1/4W 68 OHM	RES. CARBON	6 EA	R813R,R813G,R813B,R814R,R814G,R814B
2 30- 2Z0033TAX	KSP92	TR.	6 EA	Q802R,Q802G,Q802B,Q804R,Q804G,Q804B
2 30- 3Z0032TAX	KSP44TA	TR.	6 EA	Q801R,Q801G,Q801B,Q806R,Q806G,Q806B
2 21- 113900J4A	1/6W 390 OHM	RES. CARBON	7 EA	R804,R807,R809,R813,R827,R828,R829
2 34- 413550001	ATS3550L(3.5X5mm)	BEAD CORE	7 EA	L801,L802,L805,L806,L807,L808,L809
2 26- 822R0104T	DC50V-F-104PF(Z) T/P	CAP. CERAMIC	8 EA	C803,C812,C813,C814,C815,C817,C819,C822 R805R,R805G,R805B,R807R,R807G,R807B,R82
2 21- 103300J5A	1/4W 33 OHM	RES. CARBON	9 EA	2,R825,R826 D803,D803R,D803G,D803B,D806,D807,D808,D
2 35- E1N41482T	1N 4148	DIODE	10 EA	809,D810,D811 R810,R811,R814,R819,R821,R824,R832,R833,
2 21- 111000J4A	1/6W 100 OHM	RES. CARBON	11 EA	R834,R835,R836
2 43- 880052R0T	52 mm TAPING	JUMP WIRE	33 EA	J801~J833

3	KT-2914,KORTEK		1	TACT SW PCB
3 21-111000J4A	1/6W 100 OHM	RES. CARBON	1	EA R406
3 21-113300J4A	1/6W 330 OHM	RES. CARBON	1	EA R407
3 21-114700J4A	1/6W 470 OHM	RES. CARBON	1	EA R408
3 21-1202R4J4A	1/6W 2.4 KOHM	RES. CARBON	1	EA R410
3 37-110002GRA	DLL-30631, GREEN 3PI	LED,KT-XX82	1	EA D402
3 49-0526804XX	5268-04	WAFER	1	EA CN403
3 21-120100J4A	1/6W 1 KOHM	RES. CARBON	2	EA R405,R409
3 58-311105002	RT1105TA TAPING	SWITCH TACT 1970	4	EA SW401.SW402.SW403.SW404

6-2. DIFFERENT PART LIST BY MODEL

NO	CKT. NO	MODEL				
		KT-2914F	KT-2914DF	KT-2914DF	KT-2114DF	KT-2114F
1	CRT	SDI	SDI	LGP	ORION	SDI
2	C727	472,1.6KV MPP	332,1.6KV MPP	332,1.6KV MPP	332,1.6KV MPP	332,1.6KV MPP
3	C710	224,250V MPP	224,250V MPP	224,250V MPP	304,250V MPP	334,250V MPP
4	C709	564,250V MPP	524,250V MPP	524,250V MPP	824,250V MPP	824,250V MPP
5	C705	274,250V MPP	224,250V MPP	224,250V MPP	334,250V MPP	394,250V MPP
6	C702	104,250V MPP	104,250V MPP	104,250V MPP	204,250V MPP	224,250V MPP
7	T303	SCT-82D	SCT-82D	SCT-82D	SCT-82	SCT-82
8	R730	2.4K,1/6W 1%	2.4K,1/6W 1%	2.4K,1/6W 1%	3.6K,1/6W 1%	3.6K,1/6W 1%
9	R215	1.2, 1/2W	1.2, 1/2W	1.2, 1/2W	1.2, 1/2W	1.2, 1/2W
10	R216	1.2, 1/2W	2.7, 1/2W	2.7, 1/2W	4.7, 1/2W	4.7, 1/2W
11	T701	ET-14	ET-14	ET-14	NONE	NONE
12	C706	103,250V MPP	103,250V MPP	103,250V MPP	NONE	NONE
13	R715	100, 3W	100, 3W	100, 3W	NONE	NONE
14	R113	1,1W	1,1W	2.2, 3W	1,1W	1,1W
15	CRT SOCKET	SINGLE	DOUBLE	DOUBLE	SINGLE	SINGLE

7. BLOCK DIAGRAM

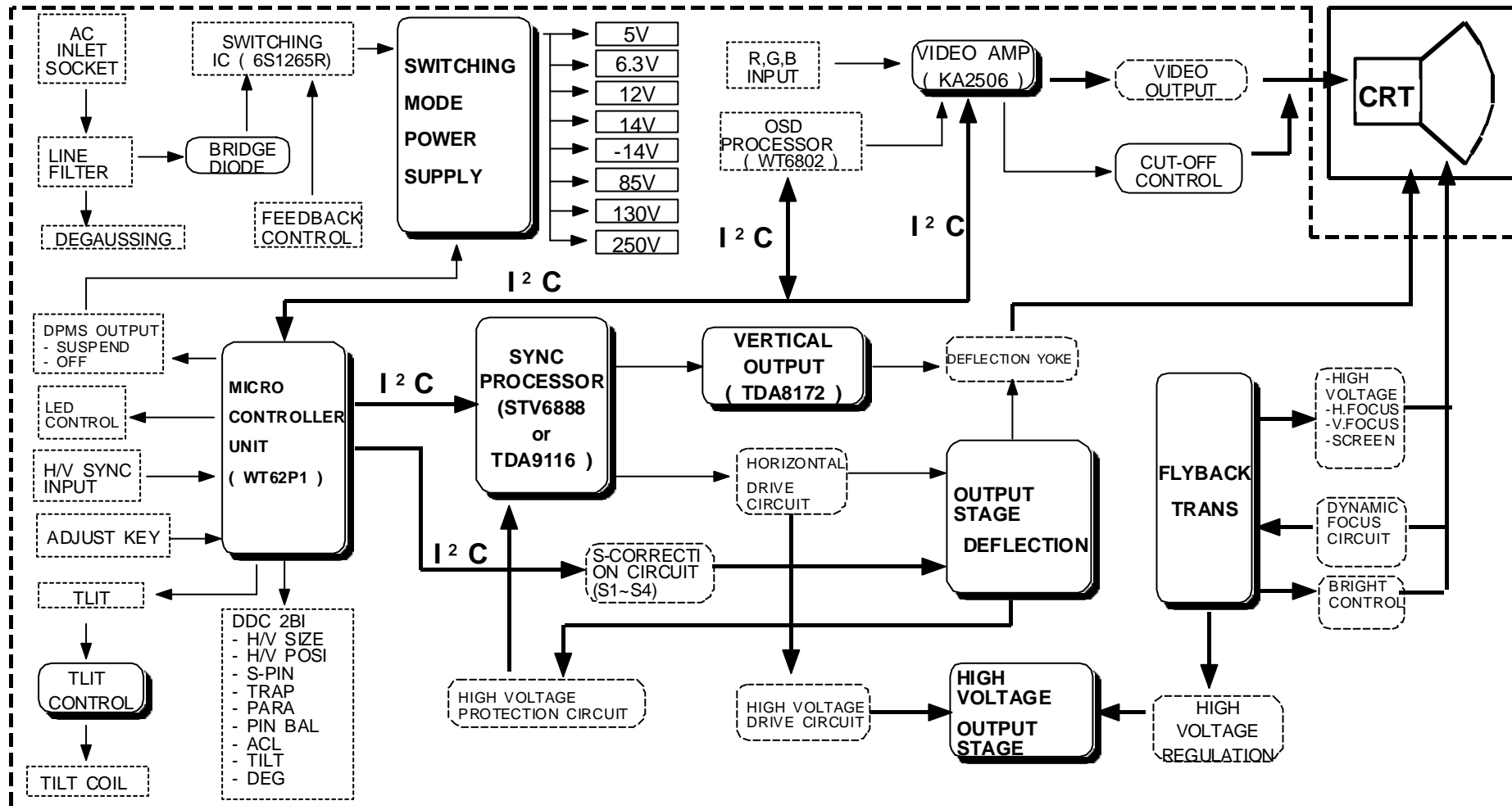

8. CONNECTING DIAGRAM

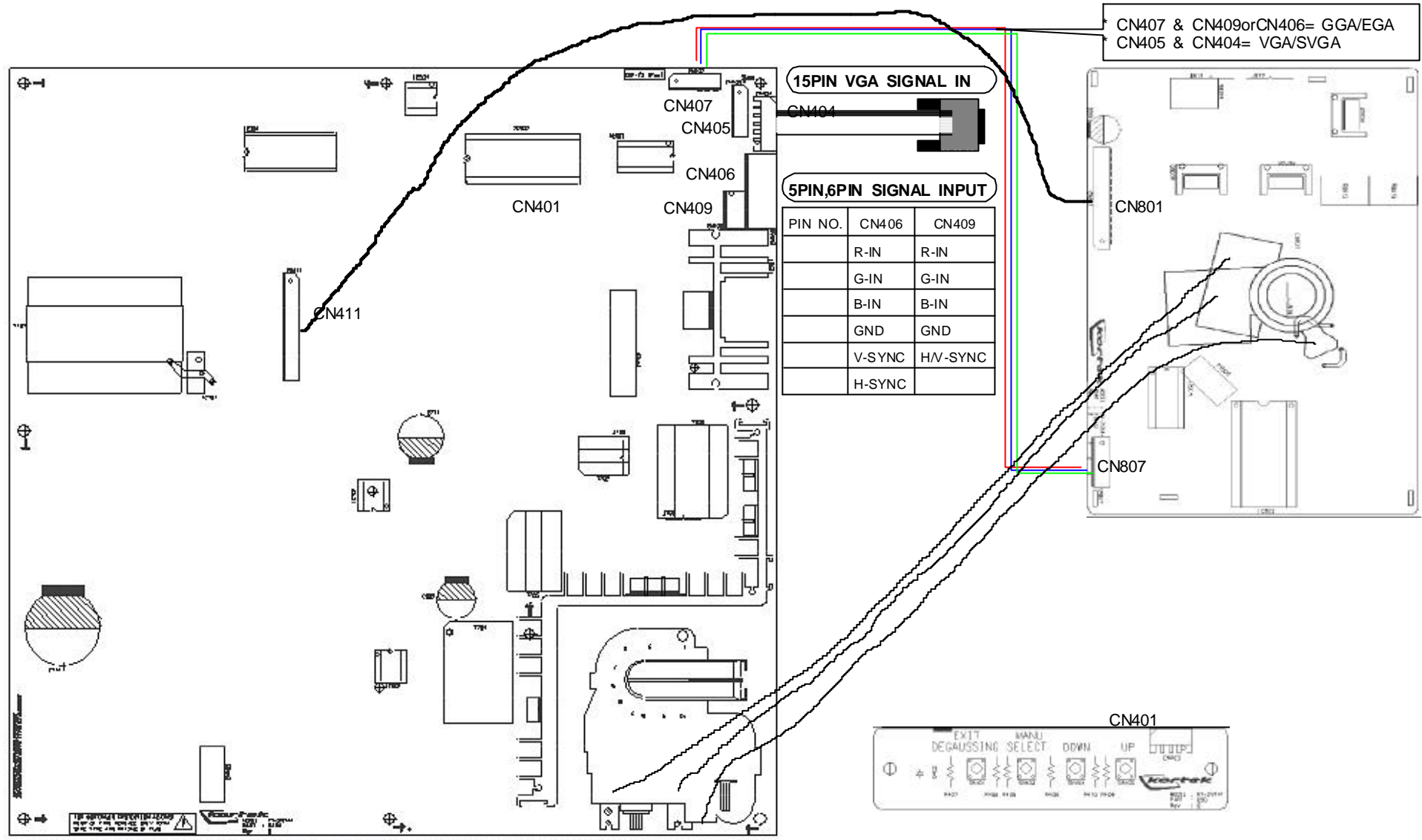

9. SCHEMATIC

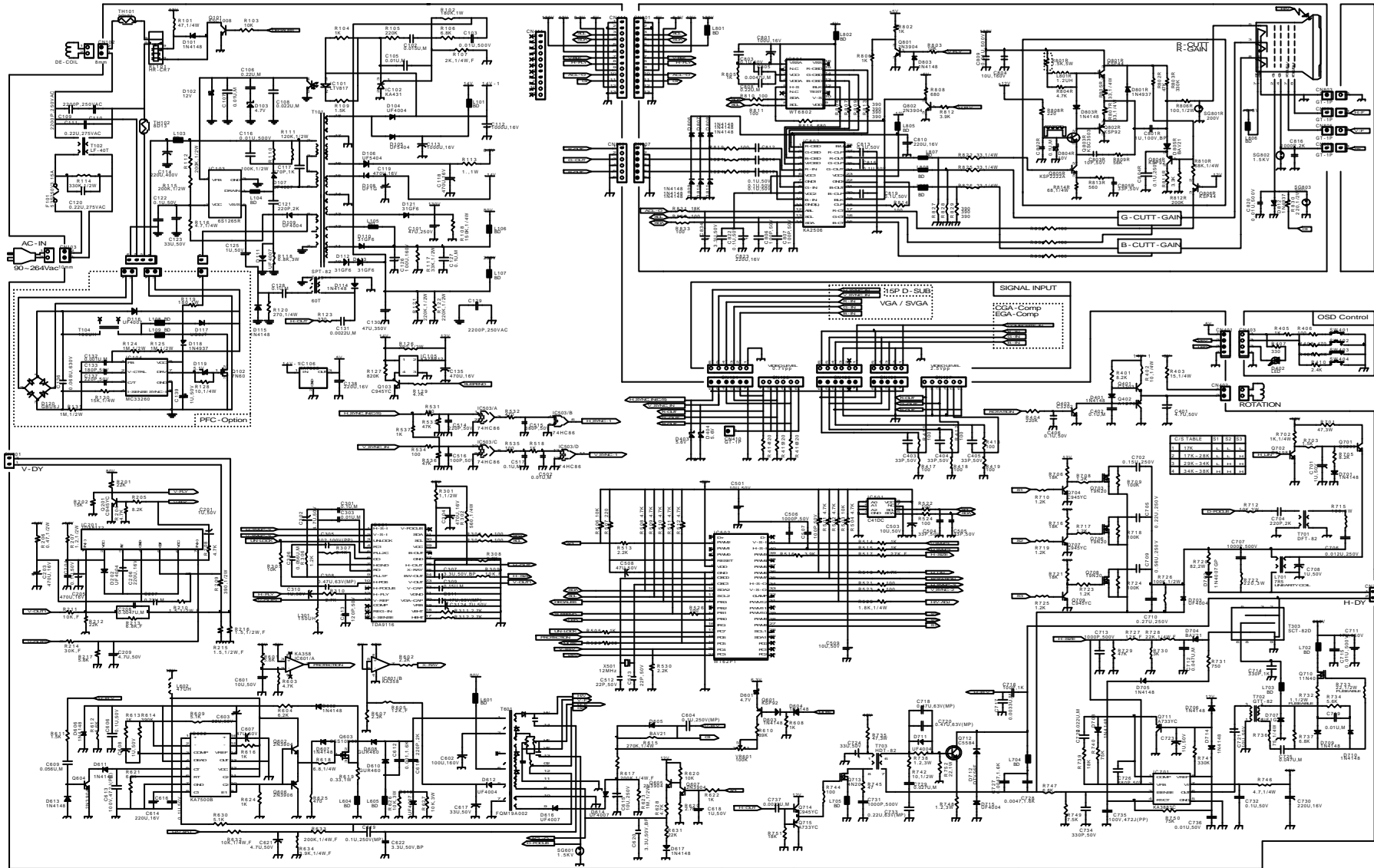

10. PRINT CIRCUIT BOARD

10-1 MAIN

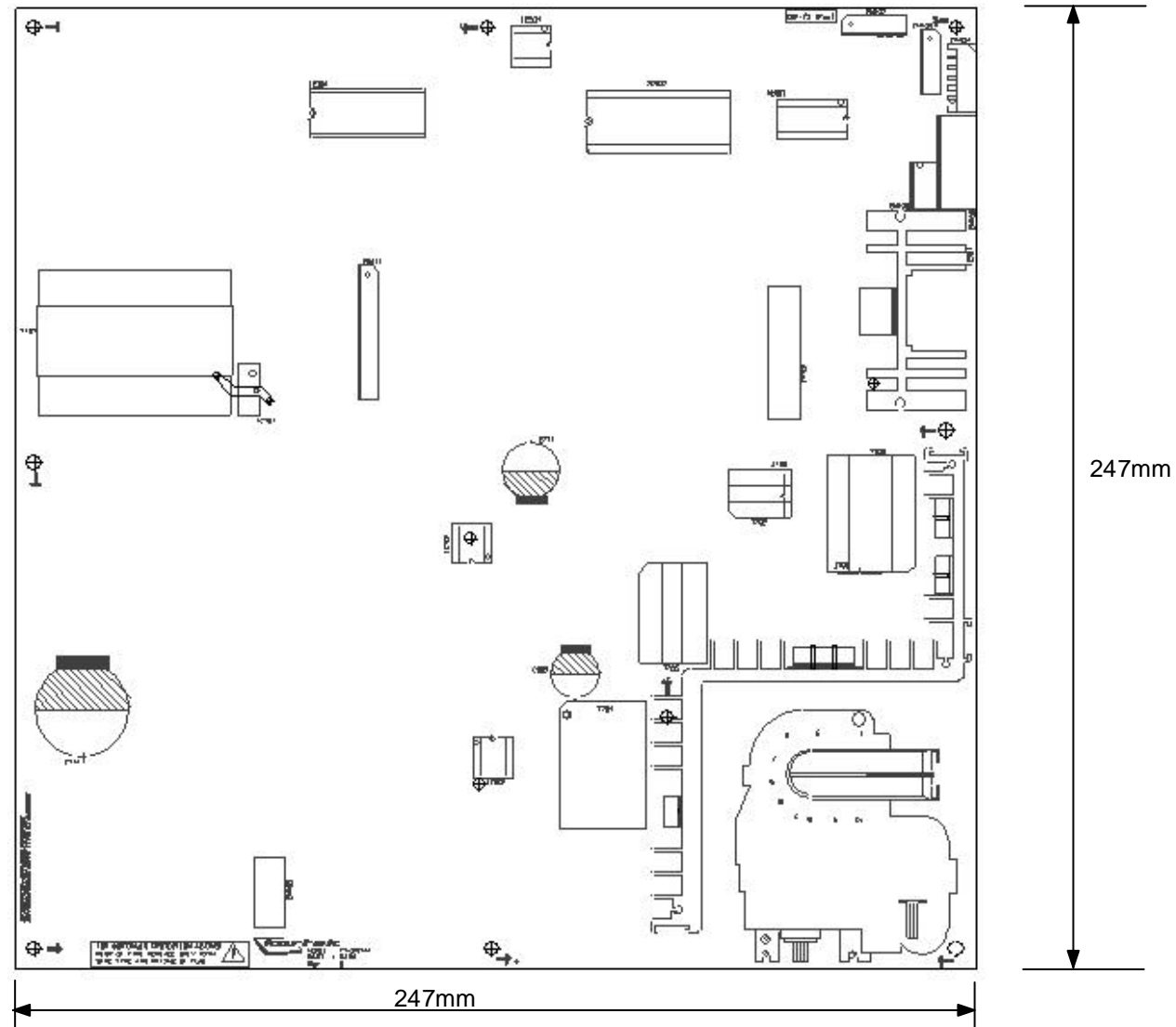

10-2 VIDEO

